



500 Series Control System & Siren Amplifier Console Mount, Remote Mount, & Handheld Part Numbers: ENGSA5 (xxxxxx)

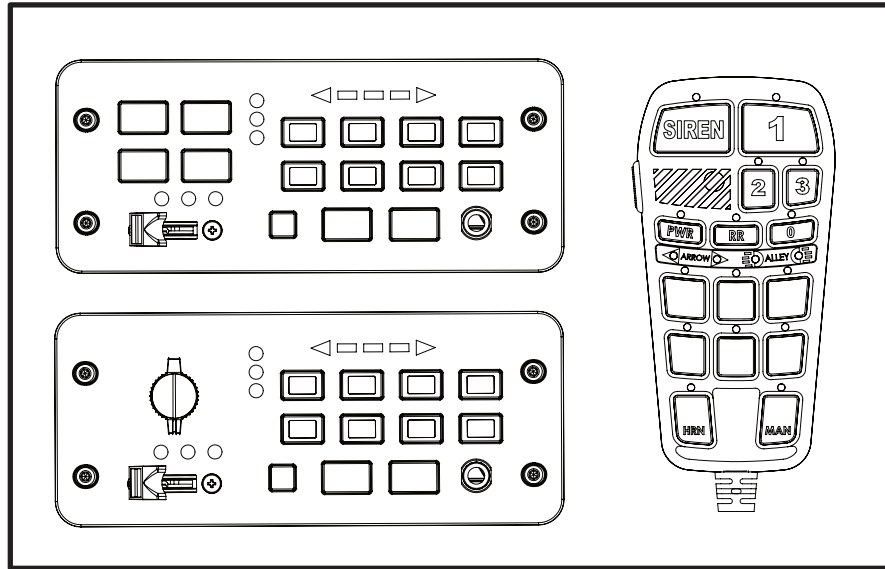

TABLE OF CONTENTS

Introduction	2
Siren System Notice	2
Caution & Notice to the Installer	2
Instructions Reference	2
Hardware Installation & Wire Routing	3
Power & Fusing	3
System Outputs	4
Lightbar Control Buses	4
Control Panel Bus #1 (Remote) & Optional Equipment	5
Control Panel Bus #2 (Console) / Siren Data Bus	5
System Inputs	5
Siren & Speaker Functions	6
Programming	6
Wire Amperage Table	6
Diagnostic Functions and Notifications	7
Tech Specs & Replacement Parts	8
Schematics	9
Horn Ring Examples	11
LIN Bus Examples	11
Lightbar Data Port Bus Examples	12
Control Panel Connectivity	12
Relay Outputs with Inductive Loads	13
External PA Mic Connection	14

⚠ WARNING

- HIGH CURRENT interconnects must be properly terminated. Poor crimp quality can cause heat build-up and fire. Follow crimp connector manufacturer instructions. Always verify that the mating terminals for high current connectors use the same plating finish.
- DO NOT install this product or route any wires in the Air Bag Deployment Zone. Refer to vehicle Owner's Manual for deployment zones.
- DO NOT use system to disconnect headlights, brake lights or other safety equipment.
- Unit may become hot to touch during normal operation.
- Failure to properly install connectors, fuses or wiring may cause equipment or vehicle failure or fire.
- Installation must only be performed by trained technician. Installer must determine vehicle wiring configuration and proper integration of system.
- Use proper wire gauge. All power wires connecting to positive (+) or negative (-) battery terminal or local chassis ground (-) must be sized to supply at least 125% of max. current and properly fused at power source.
- Install protective grommets when routing wire through firewall or metal.
- It is the installer's responsibility to verify installation of special connectors or greases as listed in this installation manual. Neglecting to do so may result in product failure and/or warranty refusal.

NOTICE:

Installers and users must comply with all applicable federal, state and local laws regarding use and installation of warning devices.

Improper use or installation may void warranty coverage. To review our Limited Warranty Statement & Return Policy for this or any SoundOff Signal product, visit our website at soundoffsignal.com/support-page/warranty/. All returned items must be properly packed to prevent damage in transit.

If you have questions regarding this product, contact Technical Services, Monday - Friday, 8 am to 5 pm at 800-338-7337 (press #4 to skip the automated message). Questions or comments that do not require immediate attention may be emailed to techgroup@soundoffsignal.com.

INTRODUCTION

Thank you for choosing to equip your vehicle with SoundOff Signal's powerful, intelligent 500 Series Control System and Siren Amplifier. This bluePRINT compatible control system has been designed from the ground up as a complete solution for even the most advanced emergency vehicle needs. It is capable of managing multiple connected devices, including lightbars, control panels, and remote input and output modules.

The 500 Series Control System has a host of new features and connections to help first responders and roadway workers complete their tasks more safely. The system's most advanced features are configurable using our SoundOff Central application for Windows. With SoundOff Central you can program input and output relationships, read vehicle data signals, build virtual inputs, and manage load-shed using voltage or timers. Additionally, you can use the diagnostics interface to validate your program and troubleshoot connections.

SoundOff Signal is excited to be your partner for safety and we offer industry-leading service and support of this and all our products. After fully reviewing these instructions, please contact us should you have questions or concerns about the installation or use of this system.

SIREN SYSTEM NOTICE

Sirens provide an essential function of an effective audio/visual warning system and are required in most states for emergency vehicles operating under statutory exemptions.

However, sirens are only short-range secondary devices. The use of a siren does not ensure that all drivers can or will abide by or react to an emergency warning signal, especially at high rates of speed or long distances. The operator of the vehicle must never take the right of way for granted, and it is the operator's responsibility to proceed safely.

The reliability and effectiveness of this siren system is highly dependent on the correct mounting and wiring. The installer must read and follow the manufacturer's installation instructions and warnings in the manual. The vehicle operator should routinely verify that the siren system is securely fastened to the vehicle and properly functioning.

Effective sirens generate loud sound pressure levels that can potentially cause hearing damage. Installers and those around the vehicle need to be aware of these dangers and wear hearing protection whenever the siren system is operating. Vehicle operators and occupants should assess their exposure to siren noise and determine what steps need to be taken to prevent hearing damage.

The siren system is intended for use by authorized personnel only. It is the user's responsibility to ensure they understand and operate the emergency warning devices in compliance with all applicable city, state and federal laws and regulations. SoundOff Signal assumes no liability for any loss resulting from the installation and use of the siren system.



SYSTEM SCALABILITY

The 500 Series Control System is a scalable system that can fit any user's needs. The below table shows how this system can be scaled up to include additional inputs, outputs, and to increase total potential switching current:

Device	# Of Inputs	# Of Outputs	Total Potential Switching Current (Amps)
500 Series Control System	9	21	75
bluePRINT Link®	24*	-	-
bluePRINT Input Node or Lightbar Breakout Box	20	-	-
Remote Nodes (Up to 5)	20	50	250
TOTAL	73	71	325 Amps

*bluePRINT Link allows the programmer to choose from more than 50 vehicle signals for each of the 24 system inputs.

In addition, the 500 Series Control System has built in CAN and LIN Data BUS ports allowing for future growth.

CAUTION & NOTICE TO THE INSTALLER

Make sure to read and understand all instructions and warnings before proceeding with the installation of this product. Ensure the manual and all warning cards are delivered to the end-user of this equipment. It is your sole responsibility to install this product in accordance with known automotive electrical best practices. Vehicle modification is done at the sole risk of the modifier and should follow vehicle manufacturer guidelines.

INSTRUCTIONS REFERENCE

Plug & Pin Referencing

Throughout this installation manual, references to pin numbers and plug numbers will typically be shown as CN4.2 or CN11. When referencing these positions, here is how that translates:

- CN4.2 – Connector CN4, Pin #2 specifically
- CN11 – Connector CN11 (as a whole)

The connectors are referenced on the backside of the siren as CN#.

HARDWARE INSTALLATION & WIRE ROUTING

Amplifier Installation (Remote Mount)

Locate a suitable mounting location. We recommend a cool, dry area. Before drilling holes, check for clearance to prevent damage to the amplifier or any other components being installed. Check both sides of the mounting surface before drilling and be aware of any vehicle components or other vital parts that may be damaged during drilling. It is the installer's responsibility to verify this information.

WARNING: DO NOT MOUNT COMPONENTS IN OR ROUTE WIRING THROUGH AIR BAG DEPLOYMENT ZONES.

1. Slide ¼" hex head bolts into siren amplifier t-slots.
2. Place mounting brackets over bolts. Adjust forward or rearward as needed.
3. Thread ¼" lock nuts onto bolts and tighten down.
4. Mark the anchor points where the amplifier is to be mounted.
5. Remove the amplifier from the mounting area.
6. If necessary, pre-drill any mounting holes into the mounting surface.
7. Secure the amplifier to the mounting surface with the included hardware.

Control Panel Installation (Remote Mount w/ Optional Bail Bracket PSRN5BLBK1)

Find a suitable location for the remote-mounted Control Panel. We recommend a cool, dry area. Before drilling any holes, check for clearance to prevent damage to the control panel or any other components.

WARNING: DO NOT MOUNT COMPONENTS IN OR ROUTE WIRING THROUGH AIR BAG DEPLOYMENT ZONES.

1. Install the bail bracket using the included screws and square nuts.
2. Mark the installation location anchor points where the bail bracket is to mount to the surface.
3. Remove the control panel and bail bracket from the mounting area.
4. If necessary, pre-drill any mounting holes into the mounting surface.
5. Secure the bail bracket to the mounting surface with the included hardware.

Console Mount Sirens

Console mount sirens are intended to be mounted into a prefabricated or aftermarket console. Follow the directions for mounting equipment into the aftermarket console. For best results use equipment-specific brackets or faceplates.

POWER & FUSING

Main Power & Fusing

WARNING: TO AVOID DAMAGE OR INJURY, DO NOT CONNECT POWER WHEN CIRCUIT IS LIVE. Install fuse only after all connections are verified to be correct and secure.

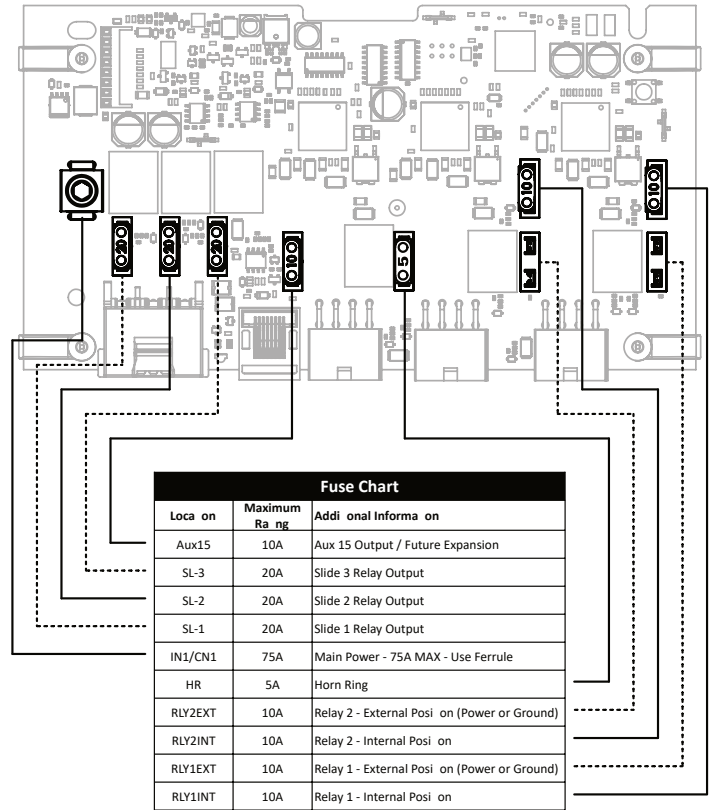

See the image above. Connect 12 VDC power directly to the screw-down block on the upper control board inside the siren (left side of image.) Use a 1/8" Allen/hex wrench and torque to the recommendation shown on the table to the left. There is a provided pass-through hole in the siren for routing this power circuit into the siren, labeled CN1 on the back cover. When making the connection, be sure to use either of the included wire ferrules to provide a tight and secure connection.

NOTICE: WIRE FERRULES MUST BE USED. DO NOT TIGHTEN THE BLOCK ON BARE WIRE.

We recommend crimping the ferrules using the manufacturer recommended crimpers (SQ28-10 or TRAP24-10) or equivalents.

The chart on the next page shows the recommended ferrule size for the supply circuit size as well as the recommended wire gauge for state and internal relays (CN2, CN4, CN5 & CN6). The upper control board is rated for no more than 75A total. When fusing, use a fuse rated for 125% of the total switched current in your application.

PLEASE NOTE: The wire and ferrule combination determine the maximum amperage throughout for the connection, based on ferrule to wire surface contact. These ratings are recommended by the connector manufacturer.

NOTICE: TO PREVENT STRAIN ON ALL CONNECTORS AND TO ALLOW FOR EASE OF FUTURE SERVICEABILITY, WE RECOMMEND INSTALLERS LEAVE SUFFICIENT EXTRA LENGTH OF WIRE TO PROVIDE A SERVICE LOOP. THIS SERVICE LOOP SHOULD BE SECURED TO THE INSTALLATION PLATFORM OR A TIE DOWN POINT.

Ferrule Color	Wire x AWG	Max. Ferrule Current*	Rec. Torque
Red	1 x 4ga	75 Amps	45 In/Lbs
Red	2 x 8ga	67 Amps	45 In/Lbs
Red	1 x 6ga	53 Amps	45 In/Lbs
Yellow	2 x 10ga	42 Amps	40 In/Lbs
Yellow	1 x 8ga	33 Amps	40 In/Lbs
Yellow	1 x 10ga	21 Amps	35 In/Lbs

**This is the maximum amount of current the wire ferrule can transfer.*

- Always use both the ferrule and rubber wireguard.
- Inspect for stray strands that could cause a short circuit. Verify strands do not protrude more than 4mm (.15") beyond lug.
- Always consult wiring standards for specific application, wire type, and ferrule size.
- Always use recommended lug torque.
- When torquing, we recommend holding torque pressure for 5 seconds, to aid in torque stability. DO NOT USE THREADLOCKER.
- Always size wire to allow for 125% of current.
- Do not solder wires to be used in the lug. This can cause loosening over time.

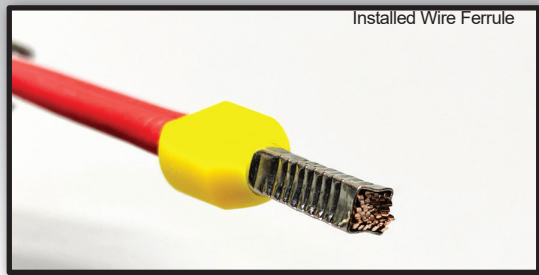

Siren Amplifier Power, Ground and Fusing

CN1 2.1 and CN1 2.2 are for the siren amplifier power and ground. The siren amplifier is externally fused on the back panel, with either a 15A or 25A fuse for 100/200 watt systems.

In addition, we recommend fusing the power circuits to protect the wiring between the power source and the siren amplifier itself – unless the amp is within 18" of the power source.

For CN1 2.1, we recommend fusing the power circuits at 15A for 100w siren systems and 25A for 200w siren systems.

Route CN1 2.2 to the vehicle's chassis, preferably to a factory grounding point. We do not recommend grounding with a self-tapping screw.

Internal Relay Fuses

There are seven internal fuses for the various relays on the 500 Series Control System which are all user-serviceable. Please see the diagram on page 3.

SYSTEM OUTPUTS

CN2 - 20A High Current Relay Outputs

Each of the outputs on connector CN2 is rated for 20A. The relay outputs are capable of constant steady power. These outputs can be paralleled where necessary.

NOTE #1: The total current for these three outputs should not exceed 50A.

NOTE #2: Depending on when the 500 Control System was ordered, CN2 may have differing connector materials - either tin or gold. Always verify that the mating connectors use the same plating type. This mating connector is shipped pre-lubricated with NyoGel 760g Dielectric Grease.

CN5 & CN6 - 10A High Current Relay Outputs

CN5.1 – CN5.3 and CN6.1 – CN6.3 contain input and output wires for relay outputs 1 and 2. For each relay, there are three connections:

- Pins 1 & 2: – Normally Open (1), and Normally Closed (2) outputs. The resting (off) state for this relay is Normally Closed (2) being active, and Normally Open (1) being inactive.
- Pin 3 – External Input. Pins 1 & 2 can be provided external power or ground using this input. This does require moving an internal fuse, as shown on page 3.

Please Note: When using the above outputs for inductive loads that utilize a coil - such as external relays, gun locks, solenoids, or electric motors, we advise installing a shunt diode at the device to suppress transients/reverse voltage during shutdown of the circuit. This is shown on page 14. This diode should be rated at a minimum of 100v at 1a.

CN4, CN5 & CN6 - Solid State Programmable Outputs

Connectors CN4, CN5, and CN6 have five solid-state outputs on each connector for outputs 1-15. These are on pins 4-8 on each plug.

Through SoundOff Central bluePRINT programming software, each output's on, and off-state as well as

flash patterns, can be prioritized and programmed. Additionally, each output's amperage shut-off threshold can be adjusted up to the 5 and 10A limits.

Each of the outputs provides diagnostic information to bluePRINT to aid in troubleshooting should it be needed at a later date. The output circuits and amperage limits are shown on the schematics on page 9.

Each connector has an output that is diode isolated (pin 5), and an output that allows for inrush (start-up) surging (pin 6). These are detailed on the schematics, shown on page 9.

To aid in installation, a silver wire label sheet for connectors CN4 - CN6 is included with the 500 Series Control System. The wire labels can be used to mark each harness and where it is connected. There is space on each label for the upfitter to provide additional information as needed.

LIGHTBAR CONTROL BUSES

CN3 – RJ-45 - Lightbar Data Bus #1 – RJ-45 Direct Connect

The 500 Series Control System has internal and external lightbar controls, meaning it can be used with or without a Breakout Box (B.O.B). This allows for direct connection (with no B.O.B.) using the nFORCE® Exterior Lightbar, or any of SoundOff Signal's three-wire type lightbars using an accessory RJ-45 to single wire adapter (shown on page 12, sold separately).

This port also supports connecting multiple external B.O.B.'s using parallel CAT-5 splitters. This feature can be programmed through SoundOff Central bluePRINT software.

When using more than one external B.O.B., parallel splitters may be necessary. Any parallel splitter will work to provide extra RJ-45 connection points.

Please note – Crossover splitters, Ethernet Routers, and Ethernet Switches are not the same thing as a parallel splitter and will cause data transmission problems.

Lightbar data bus #1 and #2 can be controlled independently.

CN4.3 – Lightbar Data Bus #2 – Single Wire Direct Connect

A second lightbar channel is provided for connecting an additional data controlled lightbar (mpower®, nFORCE® Interior Lightbar, nFUSE®). No B.O.B. is needed for this connection. Through SoundOff Central bluePRINT programming software, lightbar data bus #1 and #2 can be controlled independently.

Lightbar Data Bus Connectivity

See the data bus connectivity schematic on page 12.

CONTROL PANEL BUS #1 (REMOTE) & OPTIONAL EQUIPMENT

Control Panel Bus #1 is located on the rear panel of the siren amplifier. It is designated CN11.

CN11 – RJ-45 – Remote Control Panel

When using a remote mounted control system, connect the remote control panel here using a standard Ethernet patch cable (not cross-over). Alternately, if using a console-mounted system, a secondary control panel can be connected here.

CN11 – RJ45 – bluePRINT Link ®

bluePRINT Link is an add-on component for bluePRINT that passively scans the host vehicles CANBUS for data signals that can be utilized in programming. bluePRINT Link Connects to the CN11 RJ-45 port, or it can connect to the control panel itself provided it is on the Control Panel Data Bus / Remote Control Panel Bus (as shown on page 12).

See the bluePRINT Link installation guide for more information.

CN11 – RJ-45 – bluePRINT Sync ®

bluePRINT Sync is an add-on component for bluePRINT that keeps all equipped vehicles in perfect synchronization of flash patterns. bluePRINT Sync connects to the CN11 RJ-45 port, or it can connect to the control panel itself provided it is on the Control Panel Data Bus / Remote Control Panel Bus.

See the bluePRINT Sync installation guide for more information.

CN11 – RJ-45 – Using Parallel CAT-5 Splitters

Between the Control Panel, bluePrint Link, and bluePRINT Sync, parallel splitters may be necessary. It is recommended to use the provided RJ-45 splitter to increase connection points.

Please note – Crossover splitters, Ethernet Routers, and Ethernet Switches are not the same thing as a parallel splitter and will cause data transmission problems.

CN11 – RJ-45 – Control Panel Databus Connectivity

See the data bus connectivity schematic on page 12.

CONTROL PANEL BUS #2 (CONSOLE) / SIREN DATA BUS

Front Side / Board Mounted RJ-45 – Console or Remote Control Panel (Siren Bus)

Console mount siren amplifiers have connectivity between the Control Panel and the siren amplifier using a short Ethernet patch cable (not cross-over) at the front of the amplifier (internal). When using a remote mount siren amplifier, a secondary panel can be connected to this port to provide further system control.

Control Panel Bus #2 / Siren Data Bus Connectivity

See the data bus connectivity schematic on page 13.

SYSTEM INPUTS

CN4.1 – CN 4.2 – Horn Ring Circuit

Connections CN4.1 and CN4.2 operate the horn signal function for the OEM horn. When active, the horn signal will not pass through to the OEM horn, and instead will be processed by the 500 control system.

CN4.2 is connected to the horn ring signal (from the vehicle horn circuit). CN4.1 is the output, returning back to the horn ring circuit.

SoundOff Central bluePRINT software allows custom programming of when the horn ring is active as well as additional function based on horn ring sense. In the software, CN4.2 is referred to as “Horn Ring Sense,” and this is mapped by default in new programs to the Horn Ring Secondary Trigger output.

Additionally, the Ignition input (CN7.1) is mapped by default to the “Horn Ring Rules Enabled” output. When active, these rules allow bluePRINT to process horn ring input functionality.

High Current Horn Ring - When routing a positive horn ring through the horn ring circuit, the input and output amperage should be limited to 5A. If exceeding 5A, please use an external relay to handle the amperage as shown in the image on page 11. This requires an output to trigger the relay when horn ring transfer is desired.

CN7.1 – System Ignition Input

This is the primary ignition input for the 500 Series Control System. This input controls when the system turns on and when it goes into the system shutdown timer state.

Through SoundOff Central bluePRINT programming, the system can be set to stay active for a specified time after ignition shut down – up to 18 hours. Additionally, any outputs that are activated by ignition can also be programmed to remain active independently for a specified time frame.

As an alternative, Input #1 on any remote node or Input #12 on the Input Node can be set to wake up the bluePRINT system. This needs to be programmed using SoundOff Central bluePRINT software.

When connecting ignition to this circuit, it should be fused at 3A.

CN7.3 - CN 7.6 - Pulse Width Modulation Inputs

Inputs CN7.3 – CN7.6 average the input signals allowing them to work with Pulse Width Modulation (PWM) more efficiently. This feature needs to be activated in the SoundOff Central bluePRINT Software. It is not on by default.

Vehicle OEM's typically use pulse width modulation frequencies from 100 to 250 Hz.

PWM is measured in Duty Cycle - referring to "on" time in each cycle. Below is an example of different common duty cycles.

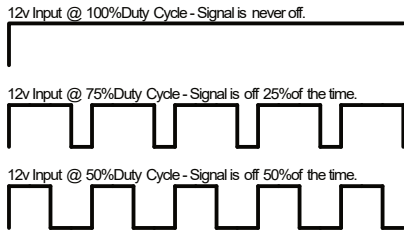

Vehicle manufacturers commonly use PWM to control vehicle brightness, including headlights, parking lights, and interior lights.

CN7.2 - CN7.9 - Discrete Inputs 1-8

Through SoundOff Central bluePRINT Programming, each of these inputs can be customized and mapped to control different outputs. All of these inputs can be set to high polarity (positive) or low polarity (ground).

SIREN & SPEAKER FUNCTIONS

CN8 – Siren Speaker Outputs

The Orange and Orange/Black wire pair is the primary speaker (A) output on a 100 or 200-watt system. For 200-watt systems, the Green and Green/Black speaker outputs drive the secondary speaker (B). When extending the wiring to the siren speaker, use a minimum of 16ga wiring.

Please note: There is no polarity requirement for these outputs. Either output can be considered positive or negative.

CN9.3 & CN 9.6 – Radio Rebroadcast

The two blue wires on CN9 are reserved for Radio Rebroadcast functions. Radio Rebroadcast allows the siren amplifier to broadcast radio transmissions through the siren speaker. Radio Rebroadcast will not work if the signal is driving remotely amplified speakers, since the signal amplitude is likely too low.

Locate the two wires that connect the external speaker to the two-way radio. Splice one blue wire into one of the external speaker wires. Splice the other blue wire into the other external speaker wire. If the blue wires need to be extended, use a minimum of 20ga wire.

Radio Rebroadcast Volume

Radio Rebroadcast volume must be adjusted before placing the vehicle into service. Volume can be set through the SoundOff Central bluePRINT Software.

PA Microphone

The PA Microphone in bluePRINT is a specialized high gain microphone that connects via a 1/4" TRS (Tip/Ring/Sleeve) audio jack on the front of the control panel.

For some remote amplifier installations, connecting the PA Microphone to the control panel isn't desirable. As an optional installation, the PA Microphone can be connected directly to the siren amplifier, using accessory kit PSRN5HDK3 or PSRN5HDK4.

The accessory kit includes an additional microphone jack and an internal adapter cable, and optionally a 20' TRS extension cable allowing the microphone to be removed from the control panel, and connected directly to the siren amplifier.

On pages 12-14 are examples of both types of installations.

PA Volume

PA volume is set using SoundOff Central bluePRINT Software.

CS1 - bluePRINT Announce In-Cabin Speaker

bluePRINT Announce is a messaging feature that allows the 500 Control System to broadcast messages over the PA speaker outside of the vehicle or through a customer-supplied in-cabin speaker. It is fully customizable using SoundOff Central Software.

PA speakers have no additional requirements other than those listed for siren functions in this manual. Customer-supplied in-cabin speakers should meet the following specifications:

- 3.5mm TRS audio input plug
- Amplified and powered with + 12vdc
- 15-watt* amplification
- Has a volume control knob (customer option).

*Recommended output for comfortable in-car audio levels.

PROGRAMMING

CN1- USB Port

All programming for bluePRINT is performed through this port. Connected lightbars can also be configured through this port.

Programming & Troubleshooting

SoundOff Central bluePRINT Software allows for programming of bluePRINT.

WIRE AMPERAGE TABLE

		AMPERAGE														
		1	2	3	4	5	7.5	10	15	20	25	30	40	50		
WIRE GAUGE	20	25.6	12.8	8.5	6.4	5.1										
	18	40.7	20.3	13.6	10.2	8.1	5.4									
	16	64.7	32.3	21.6	16.2	12.9	8.6	6.5								
	14		51.4	34.3	25.7	20.6	13.7	10.3	6.9	5.1						
	12			81.7	54.5	40.9	32.7	21.8	16.3	10.9	8.2	6.5	5.4			
	10				86.6	65.0	52.0	34.7	26.0	17.3	13.0	10.4	8.7	6.5	5.2	
	8						82.7	55.1	41.3	27.6	20.7	16.5	13.8	10.3	8.3	
6							87.6	65.7	43.8	32.9	26.3	21.9	16.4	13.1		
4									16.7	52.2	41.8	34.8	26.1	20.9		

LENGTH (IN FEET)

NOTICE:

- These figures are calculated assuming battery voltage at 12.8 VDC. This accounts for equipment that may be running with the engine off.
- Don't forget the wire length accounts for the total length of the circuit - from power supply through the load device to ground termination.
- This table was calculated with a target voltage drop at 2% of less.
- Finally, be sure to calculate wire length assuming 125% load capacity.

DIAGNOSTIC FUNCTIONS AND NOTIFICATIONS

Resetting Outputs

Should any of the solid state outputs shut off due to a fault condition, the output will need to be reset. A diagnostic check should be conducted prior to a reset.

Resetting can be done in three different ways:

- Through the SoundOff Central bluePRINT software
- By pressing the reset button shown at the top right of the board
- By connecting the programmed reset wire to ground typically with a user supplied momentary switch. This function can be programmed to any input, using SoundOff Central bluePRINT.

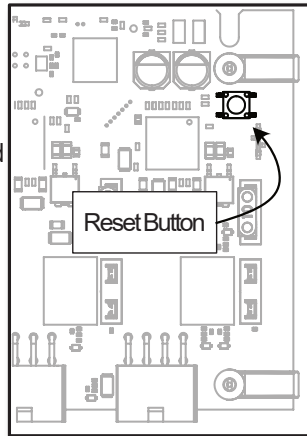

Diagnostic Status LED Lights (Control Panel)

The control panel can also indicate additional system faults, as detailed in the below table.

S1	S2	Diag	Condition
On	On	Flashing	Over Temperature
Off	On	Flashing	Under Voltage
On	Off	Flashing	Over Voltage
Flashing	Off	Flashing	Comm Fault - Relay
Off	Flashing	Flashing	Comm Fault - Amp
Flashing	Flashing	Flashing	Comm Fault - Relay & Amp
On	Off	Off*	Speaker 1 Active
Off	On	Off*	Speaker 2 Active
On	On	Off*	Speaker 1 & 2 Active
Off	Off	Off*	Speaker 1, 2, or both is not functioning.

*While the siren mode is active

Diagnostic Status LED Lights (Rear of Amplifier)

There are two different LED lights on the rear of the amplifier. Each LED light represents a different portion of the siren function.

The upper light is marked "OUTPUT STATUS." The lower light is marked "INPUT STATUS." Please see the below tables showing what the codes mean.

The error code sequence start and finish is indicated by a long orange pulse. In the case there is more than one code, a short orange pulse is shown between codes.

Output Status Diagnostic Codes

Sequence	OUTPUT STATUS Condition
Steady Green	No Faults
Flashing Red	Running in Boot leader Mode
1 Red, 1 Green	Output Board Voltage Low
1 Red, 2 Greens	Output Board Voltage High
2 Reds, 1 Green	Comm Fault - Lightbar 1
2 Reds, 2 Greens	Comm Faulty - Lightbar 2
2 Reds, 3 Greens	Comm Fault - Lightbar 3
2 Reds, 4 Greens	Comm Fault - Controller Board
3 Reds, 1 Green	Output Fault - Outputs 1-15
2 Reds, 2 Greens	Output Fault - S1 - S3 Relays
3 Reds, 3 Greens	Output Fault - R1 - R2 Relays
3 Reds, 4 Greens	Output Fault - Horn Ring Relay
7 Reds, (x) Greens	Special Code, Contact Tech Support

Input Status Diagnostic Codes

Sequence	INPUT STATUS Condition
Steady Green	No Faults
Flashing Red	Running in Boot loader Mode
1 Red, 1 Green	Output Board Voltage Low
1 Red, 2 Greens	Output Board Voltage High
2 Reds, 1 Green	Comm Fault - USB Port
2 Reds, 2 Greens	Comm Fault - CAN Port
3 Reds, 2 Greens	Comm Fault - Console Control Panel Port
2 Reds, 4 Greens	Comm Fault - Output Board
2 Reds, 5 Greens	Output Fault - Remote Control Panel Port
3 Reds, 1 Green	Output Fault - LIN Data Bus (CN7.10)
4 Reds	Configuration Fault
5 Reds, 1 Green	Siren Speaker Fault - Siren A
5 Reds, 2 Greens	Siren Speaker Fault - Siren B
6 Reds	Output Fault
7 Reds, (x) Greens	Internal Error Code

TECHNICAL SPECIFICATIONS

General Information	
Amplifier Dimensions	2.63" H x 7" W x 7" D
Full Size Control Panel	3.6" H x 7.2" W x 2.1" D
Handheld Control Panel	5" H x 2.5" W x 1" D
Input Voltage	10-16Vdc (Negative Ground)
Boxed Weight	10 lbs
Operating Temperature	-40°C to +65°C
Diagnostic LEDs	Control Panel Diagnostic LEDs (3), Siren Amplifier LEDs (2) Refer to Reference Table
Siren	
Input Current	11 Amps @ 13.4 VDC - 100W System 22 Amps @ 13.4 VDC - 200W System
Standby Current	Ignition ON - 500mA Ignition OFF - <4mA
Output Power	1x100W RMS Max (11 Ohm Speaker) 2x100W RMS Max (11 Ohm Speaker)
Siren Frequency	675Hz - 1633Hz
Over Voltage Protection	Yes
Low Voltage Shutdown	Programmable
California Title 13 Compliance	Programmable
Hands Free Operation	Programmable
Speaker Protection	Short & Open
Light Control	
Solid State Outputs	6 @ 10A 9 @ 5A
Slide Switch Relays	3 @ 20A Not to exceed 50A total
Dry Contact Relays	2 @ 10A
Horn Ring Relay	1 @ 5A
Diode Isolated Outputs	3
Inrush Capable Outputs	6
Arrow Control	Programmable
Control Panel Slide Switch Positions	Off, 1, 2, 3 - Programmable
Control Panel Auxiliary Buttons	1-8, Programmable
Control Panel Siren Buttons	Standby, Wail, Yelp, Tone, Radio Rebroadcast, Manual, Air Horn - All Programmable
Maximum Switch Current	75A (Excludes Horn Ring) (Includes Relays and Solid State Switches)

REPLACEMENT PARTS & ACCESSORIES

Part #	Description
PSRN5CTRL1	500 Series Remote Control Panel - Push Button Siren Controls
PSRN5CTRL2	500 Series Remote Control Panel - Rotary Knob Siren Controls
PSRN5CTRL3	500 Series Console Control Panel - Push Button Siren Controls
PSRN5CTRL4	500 Series Console Control Panel - Rotary Knob Siren Controls
PSRN5LEG1	Replacement Button Legend Sheet for Console and Remote Panels
PSRNHHC2	Replacement Handheld Control Panel
PSRN5ANR11	Replacement Amplifier - 100w
PSRN5ANR12	Replacement Amplifier - 200w
PSRN5MC01	500 Series Microphone
PSRN5HDK1	Replacement Input, Output, & Power Harness Kit
PSRN5HDK3	Hardware Conversion Kit - Microphone to 500 Siren Direct Connect with 25 audio extension cable.
PSRN5HDK4	Hardware Conversion Kit - Microphone to 500 Siren Direct Connect without extension cable.
PSRN5MMC1	Hardware Kit - Microphone Mounting Kit
PSRN5BLBK1	Hardware Kit - Bail Bracket
PNFLBSPLT3	RJ-45 Splitter w/ Harness

HARNESS ASSEMBLY PART NUMBERS (BUILD YOUR OWN)

Part	Description
Connector CN1	Crimp Ferrule Connection (over bare wire) Ferrule Crimp Tool: American Electrical Sq28-10 (or equivalent) Installation/Extraction Tool: 1/8" Allhex Hex Key
Connector CN2*	Connector Housing: Hirose DF22R-3S-7.92C(28) Pins: Hirose DF22A-1012SCF (Tin Terminals - J21282 and lower) Pins: Hirose DF22A-1012SCF (Gold Terminals - J21284 and higher) Pin Crimp Tool (Recommended): Hirose HT103/DF22A-1012 Pin Crimp Tool (Optional): Match MOBCT1424 (or equivalent) Extraction Tool: Flat Blade Screwdriver - 1.4mm Wide Application Specification: https://bit.ly/3a54fEY
Connectors CN4, CN5, CN6	Connector Housing: Molex 3901-2080 Pins: Molex 45750-3111 (Fits 5A or 10A Outputs, 16 AWG) Pin Crimp Tool: Molex 200218-2200 Extraction Tool: Molex 1103-0044 Application Specification: https://bit.ly/3cifegs
Connector CN7	Connector Housing: Molex 3901-2100 Pins: 3900-0039 (Bag) (Low Current Connections, 18-24 AWG) Optional Pins: 3900-0038 (Reel) (Low Current Connections, 18-24 AWG) Pin Crimp Tool: Molex 63819-0901 Extraction Tool: Molex 1103-0044 Application Specification: https://bit.ly/3t5clQC
Connector CN8	Connector Housing: Molex 3901-20240 Pins: 3900-0039 (Bag) (Low Current Connections, 18-24 AWG) Optional Pins: 3900-0038 (Reel) (Low Current Connections, 18-24 AWG) Pin Crimp Tool: Molex 63819-0901 Extraction Tool: Molex 1103-0044 Application Specification: https://bit.ly/3t5clQC
Connector CN9	Connector Housing: Molex 3901-2060 Pins: 3900-0039 (Bag) (Low Current Connections, 18-24 AWG) Optional Pins: 3900-0038 (Reel) (Low Current Connections, 18-24 AWG) Pin Crimp Tool: Molex 63819-0901 Extraction Tool: Molex 1103-0044 Application Specification: https://bit.ly/3t5clQC
Connector CN12	Connector Housing: Molex 171692-0102 Pins: 76823-0322 (12AWG) Pin Crimp Tool: Molex 63825-7100 Extraction Tool: Molex 63824-0810 Application Specification: https://bit.ly/3t3W2cw

* Dielectric grease lubrication such as NyoGel 760g (or equivalent) is mandatory in cases where similar alloys are mixed, as described on page 4.

AFTERMARKET SYSTEM HARNESS OPTIONS**

	Part #	Description
911 Circuits	911.500.10	10 Foot Harness Kit - Includes all labeled circuits for connectors CN2, CN4, CN5, CN6, CN7, CN9 and CN12, at 10 feet long, and CN8 at 25 feet long. Order directly from 911 Circuits - (503) 393-3444
	911.500.25	25 Foot Harness Kit - Includes all labeled circuits for connectors CN2, CN4, CN5, CN6, CN7, CN8, CN9 and CN12, at 25 feet long. Order directly from 911 Circuits - (503) 393-3444
Patrol Power	SOSBP500-10	10 Foot Harness Kit - Includes all labeled circuits for connectors CN2, CN4, CN5, CN6, CN7, CN9 and CN12, at 10 feet long, and CN8 at 25 feet long. Order directly from Patrol Power - (833) 701-1930
	SOSBP500-25	25 Foot Harness Kit - Includes all labeled circuits for connectors CN2, CN4, CN5, CN6, CN7, CN8, CN9 and CN12, at 25 feet long. Order directly from Patrol Power - (833) 701-1930

This list is not intended to be fully inclusive or complete.

** Please verify the harness will include the proper gold or tin connectors noted in the connectors table above for CN2.

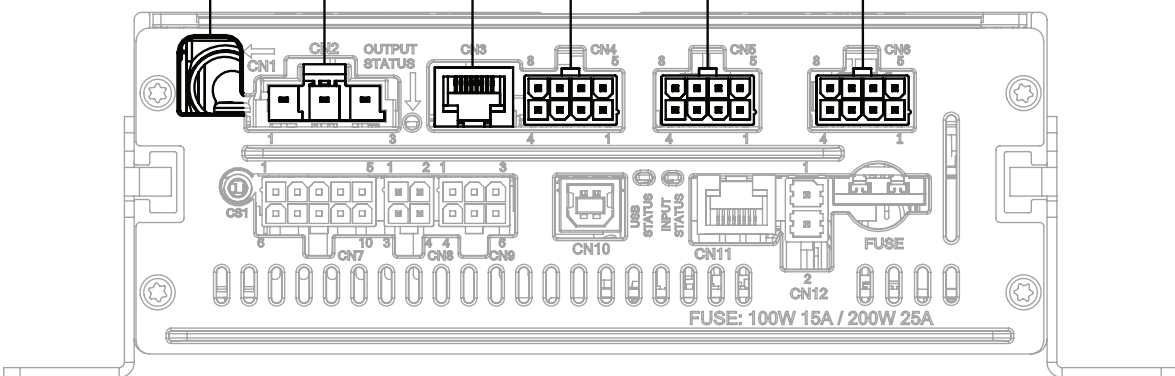
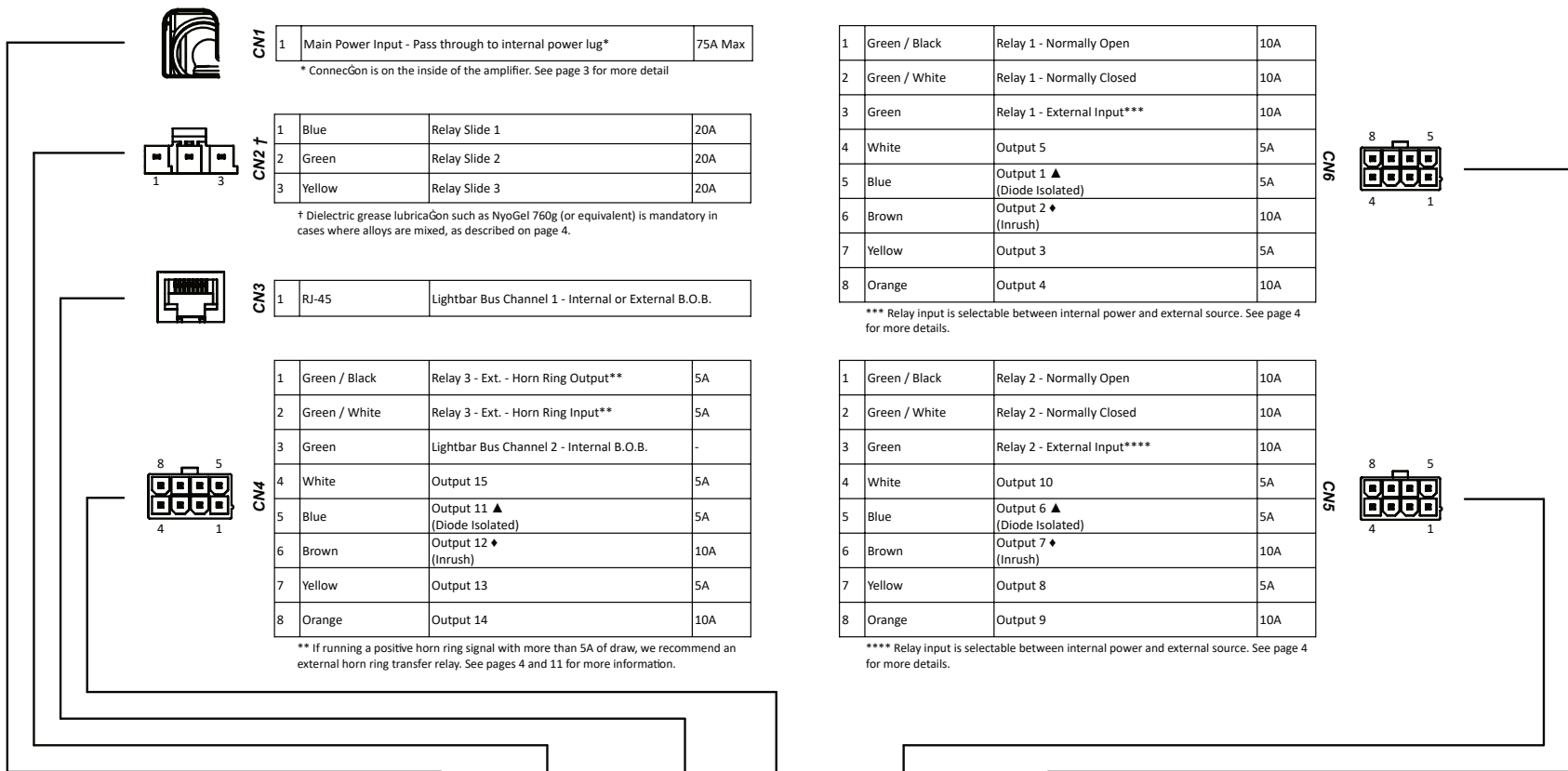

SCHMATICS

▲ = Diode Isolated
 ◆ = Inrush

CS1 - bluePRINT Announce In-Cabin Speaker
 3.5mm TRS Jack. See page 6 for more information.

Siren Amplifier Fuse
 100w = 15A
 200w = 25A

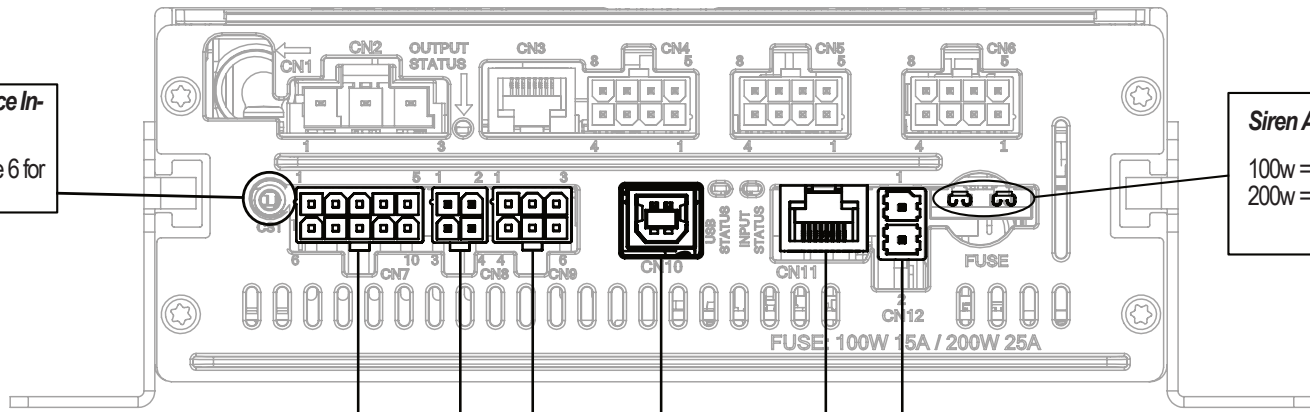

1	Orange	Speaker A Out
2	Orange / Black	Speaker A Out
3	Green	Speaker B Out
4	Green / Black	Speaker B Out

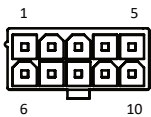

1	Orange/Black	IgniÁon Input - Fused at 3A
2	Blue	Input 1 - Hi/Low
3	Lt. Blue	Input 2 - Hi/Low/PWM*
4	Violet	Input 3 - Hi/Low/PWM*
5	Brown	Input 4 - Hi/Low/PWM*
6	Grey	Input 5 - Hi/Low/PWM*
7	White	Input 6 - Hi/Low
8	Green	Input 7 - Hi/Low
9	Pink	Input 8 - Hi/Low
10	Yellow	bluePRINT Lin Bus - Remote Nodes, Input Node**

* See page 5 for more detail on PWM.
 ** When using a lightbar breakout box as an input node, it does not get connected to this circuit.

1	Orange	Future Expansion
2	Light Blue / Red	CAN A +
3	Blue	Radio Rebroadcast / External PA Input 1
4	Light Blue / Black	CAN Shield
5	Light Blue / White	CAN A -
6	Blue	Radio Rebroadcast / External PA Input 2

1	USB B Standard	bluePRINT Programming Port
---	----------------	----------------------------

1	RJ-45 Port	bluePRINT Control Panel Bus - Remote Panel, bluePRINT Link, bluePRINT Sync
---	------------	--

1	Red	Siren Amplifier Power	15A/25A
2	Black	System Ground	

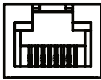
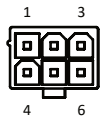

HORN RING EXAMPLES

Low Current Horn Ring - 5A Max - Positive or Negative

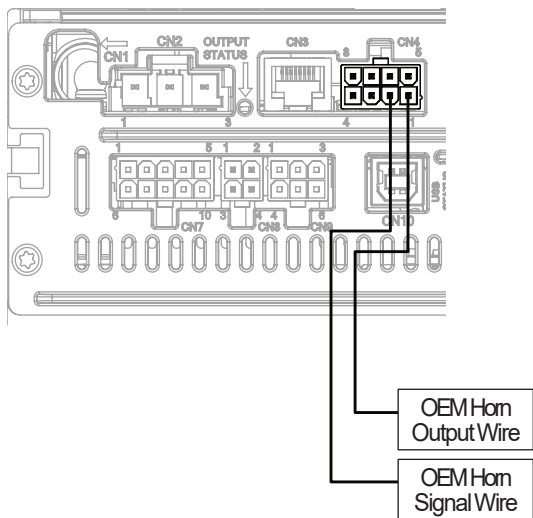

High Current Horn Ring - Above 5A - Typically Positive

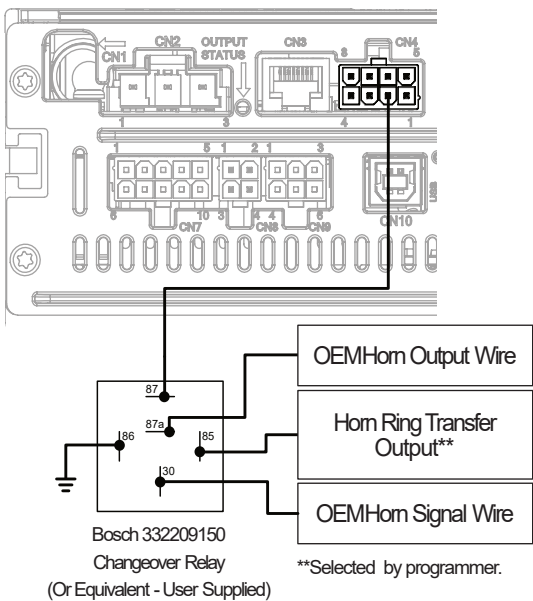

LIN BUS EXAMPLES

LIN Bus connections include Remote Nodes and Input Nodes. These can be connected using the same wire, connected in parallel, or by using junction points as shown below.

Input Nodes are only necessary when using additional discrete inputs beyond the eight provided inputs from the 500 Series Control System.

A lightbar breakout box can be configured as an alternate input node. Lightbar B.O.B.s cannot be connected here and must be connected as shown on page 12.

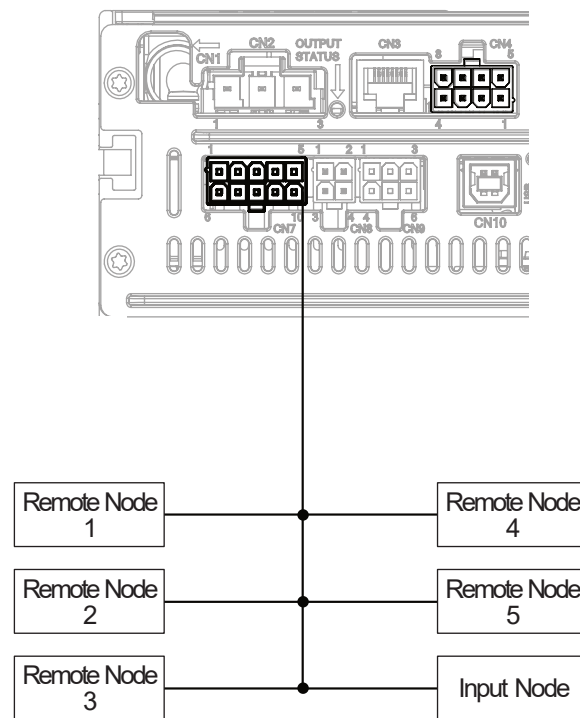

LIGHTBAR DATA PORT BUS EXAMPLES

Internal Lightbar Control Example

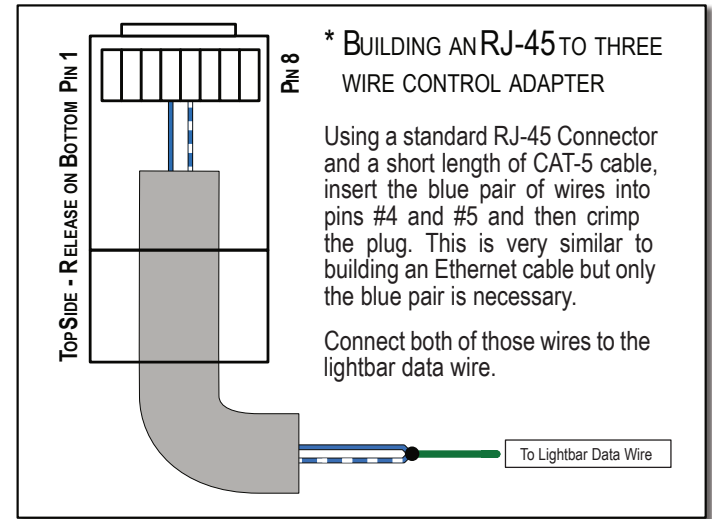
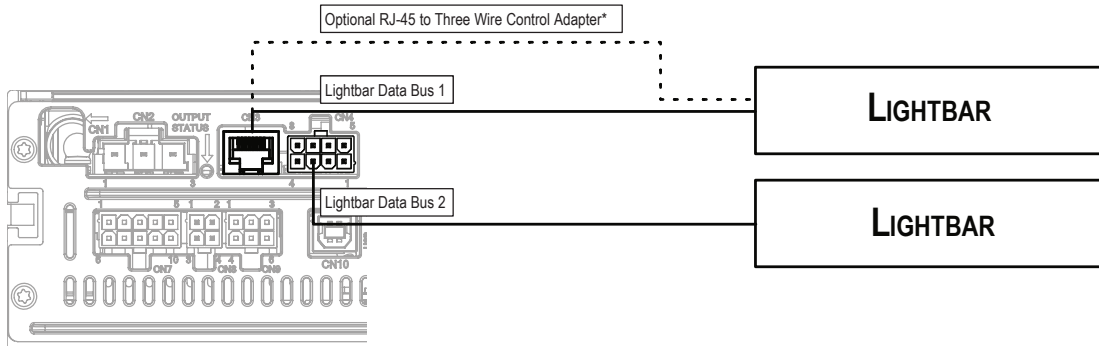

External Lightbar Control Example

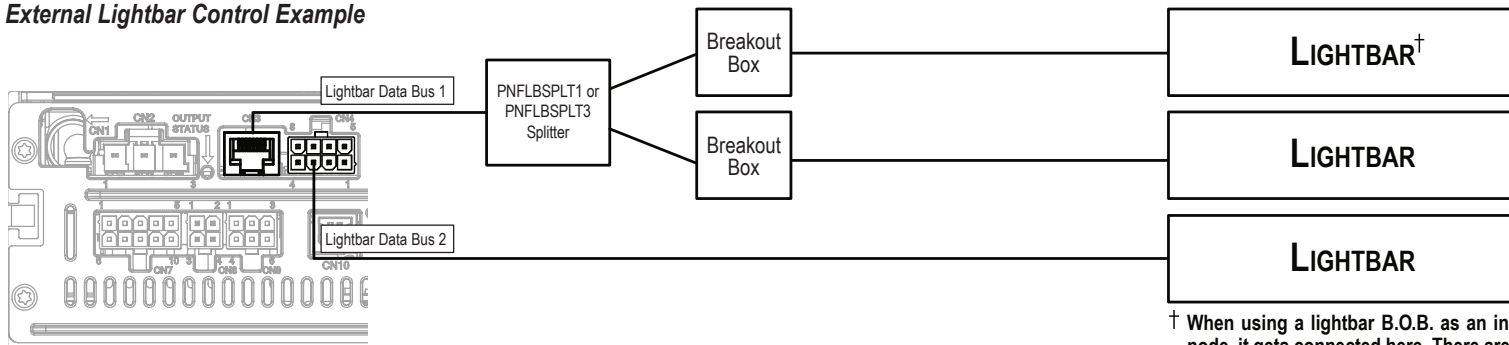

† When using a lightbar B.O.B. as an input node, it gets connected here. There are no other special requirements.

CONTROL PANEL BUS#1 (REMOTE) DATA BUS EXAMPLES

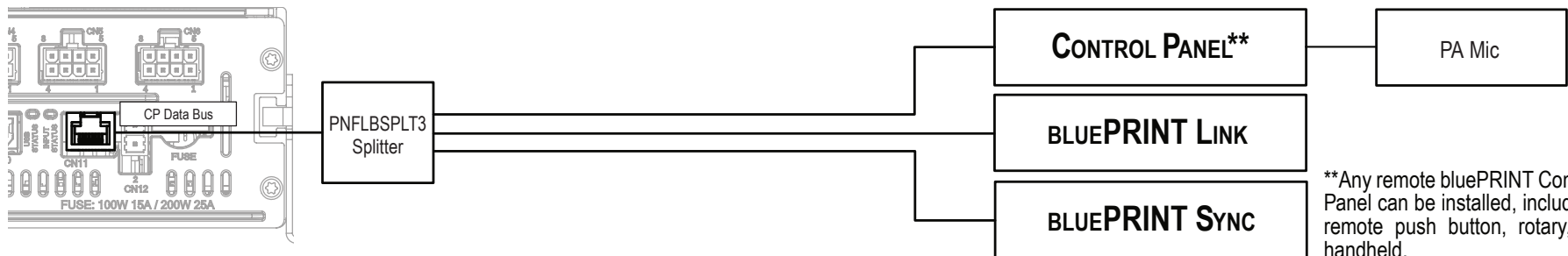

**Any remote bluePRINT Control Panel can be installed, including remote push button, rotary, or handheld.

CONTROL PANEL BUS #2 (CONSOLE) DATA BUS EXAMPLES

Console or Remote Control Panel with PA Connection at Control Panel (Inside View)

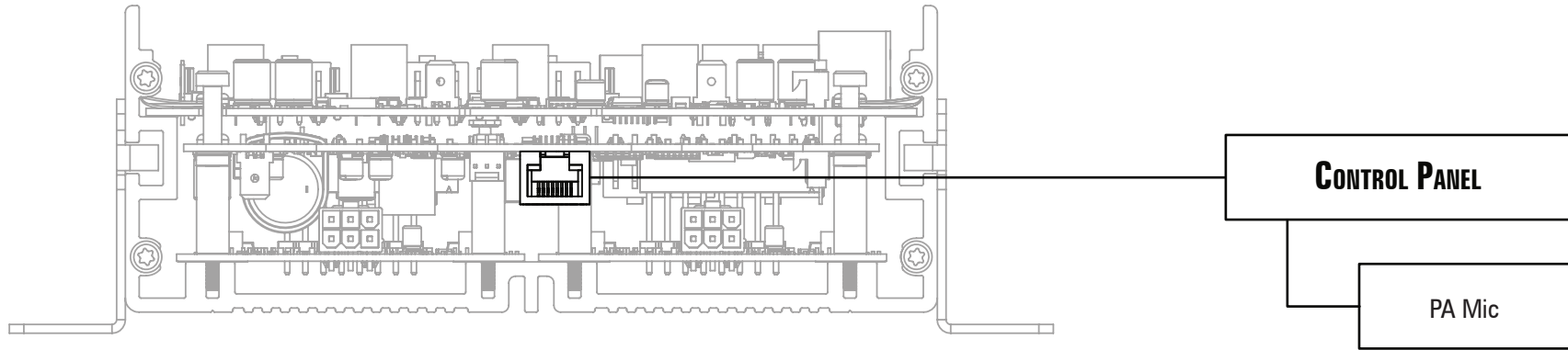

RELAY OUTPUTS WITH INDUCTIVE LOADS

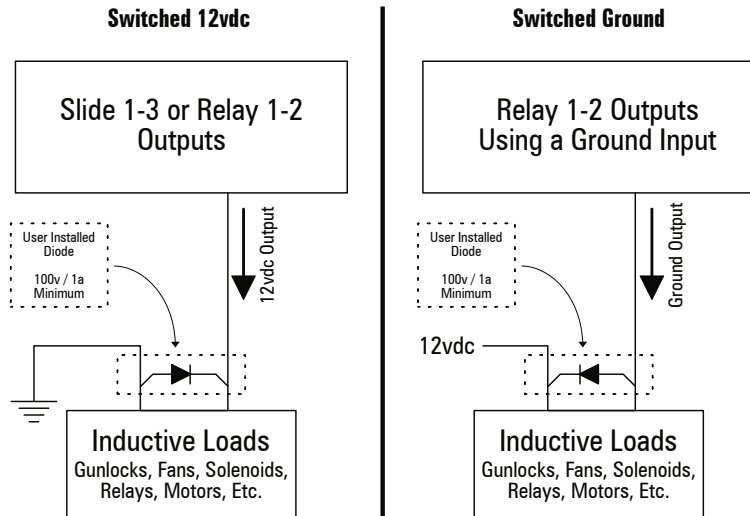

INDUCTIVE LOADS

Inductive loads are a type of electrical load found in devices that convert electrical current into a magnetic field. In electronics, this covers just about any device that utilizes a coil.

One of the characteristics of inductive loads is how it stores energy from when it is switched on. This energy store is often referred to as reactive power. When the inductive load is shut down, this reactive power is converted into stray voltage. Per the laws of electricity, this stored energy must dissipate when the load is switched off.

As a result of this characteristic, inductive loads can cause transients or "spikes" at the moment of shutdown.

To protect equipment against these spikes, we strongly recommend installing a shunt diode as shown on the diagrams to the left.

The left diagram shows how to wire the shunt diode in a positive switched circuit, and the right diagram shows the same for a ground switched circuit.

A shunt diode is nothing more than a standard diode that allows the leftover voltage to dissipate. We recommend a diode that is rated at least 100v at 1a.

In the emergency and utility vehicle industries, inductive loads cover installing any of the following devices (but are not limited to):

- Gun Locks
- Solenoids
- Relays
- Fans
- Motors
- Pumps

EXTERNAL PA Mic CONNECTION

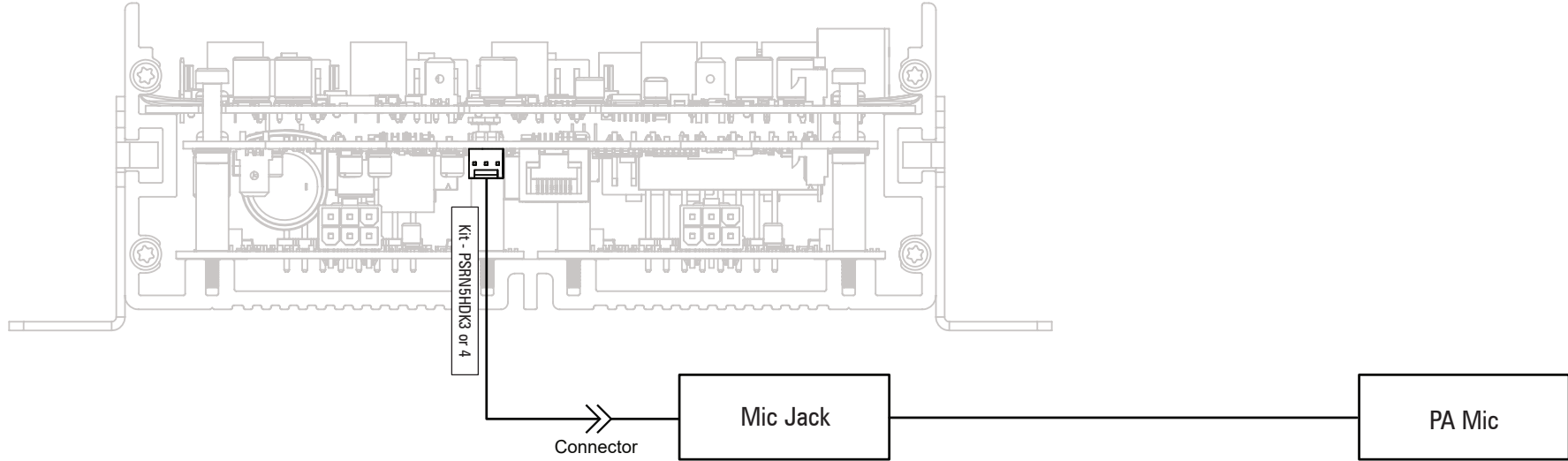

EXTERNAL PA MICROPHONE

The PC microphone can be connected in one of three ways:

- Direct to a control panel on the External Control Panel Connection (shown on pages 13 and 14)
- Direct to a control panel on the Internal Control Panel Connection (shown on pages 13 and 14)
- Direct to the middle controller board using either PSRN5HDK3 or PSRN5HDK4 adapter kits (shown above and to the right)

