

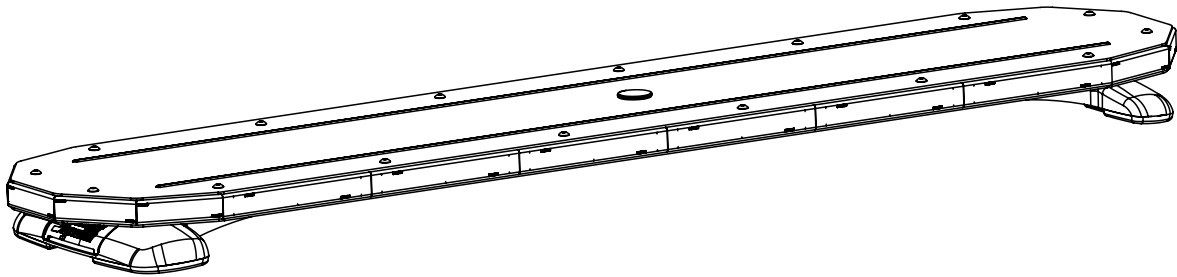

# INSTALLATION INSTRUCTIONS

## mpower<sup>®</sup> LED EXTERIOR LIGHT BAR



**IMPORTANT NOTICE TO INSTALLER:**

- Make sure to read and understand all instructions and warnings before proceeding with the installation of this product. Ensure that the manual and any warning cards are delivered to the end user of this equipment. Proper installation of the lightbar requires the installer to have a thorough knowledge of automotive electronics, systems, and procedures.
- Lightbars provide an essential function of an effective visual warning system. The use of the lightbar does not insure that all drivers can or will abide by or react to an emergency warning signal, especially at high rates of speeds or long distances. The operator of the vehicle must never take the right of way for granted and it is the operator's responsibility to proceed safely.
- The effectiveness of the lightbar is highly dependent on the correct mounting and wiring. The installer must read and follow the manufacturer's installation instructions and warnings in the manual. The vehicle operator should verify daily that the lightbar is securely fastened to the vehicle and properly functioning before operating vehicle.
- The lightbar is intended for use by authorized personnel only. It is the user's responsibility to ensure they understand and operate the emergency warning devices in compliance with the applicable city, state and federal laws and regulations. SoundOff Signal assumes no liability for any loss resulting from the use of this warning device.

**⚠ WARNING**

- This product contains high intensity LED devices to prevent eye damage, DO NOT stare into the light beam at close range.

**IMPORTANT INFORMATION:**

- To view the full Software Revision History click the  in the lower left hand corner of the SoundOff Central Lightbar application.
- Warning devices are strictly regulated and governed by Federal, State and Municipal ordinances. These devices shall be used ONLY on approved vehicles. It is the sole responsibility of the user of these devices to ensure compliance.
- DO NOT install this product or route any wires in the Air Bag Deployment Zone. Refer to your vehicle Owner's Manual for the location of any air bag deployment zones.
- DO NOT connect this device to a strobe power supply. This product is self-contained and does not require an external power supply.

**⚠ WARNING**

- Route wires only in locations that are not subject to potential wear. Make sure to avoid routing wires in the deployment area of your airbag. Refer to your vehicle's owner's manual for airbag deployment zone.
- All customer supplied power wires connecting to the positive (+) or negative (-) battery terminal or local chassis ground (-) must be sized to supply at least 125% of the maximum current and properly fused at the power source with appropriately rated fuse.

**NOTICE:**

- Installers and users must comply with all applicable federal, state and local laws regarding use and installation of warning devices.
- Improper use or installation may void warranty coverage.
- To review our Limited Warranty Statement & Return Policy for this or any SoundOff Signal product, visit our website at [www.soundoffsignal.com/tech-services/returns/](http://www.soundoffsignal.com/tech-services/returns/).
- If you have questions regarding this product, contact Technical Services, Monday - Friday, 8 a.m. to 5 p.m. ET at 1.800.338.7337 (press #4).
- Questions or comments that do not require immediate attention may be emailed to [techgroup@soundoffsignal.com](mailto:techgroup@soundoffsignal.com).

# Table of Contents



Components/Contents . . . . .	4
Module, Technical & Power Specifications . . . . .	4
Light Bar Views . . . . .	5
Fixed Height Brackets and Hook Mounting . . . . .	6 - 7
Wind Deflector Installation . . . . .	8
Function Definitions . . . . .	9
Electrical Installation . . . . .	10 - 17
Wire Function Defaults / Break out Box (BOB) . . . . .	18
Connection of Breakout Box to SoundOff Signal Sirens . . . . .	19
Siren Functions . . . . .	20
Photo Sensor . . . . .	20
LED Module Replacement . . . . .	21
Module Location ID's . . . . .	21
Replacement Parts & Accessories . . . . .	22
mPower Lightbar Troubleshooting . . . . .	23
Warranty & Return Goods Procedure . . . . .	24

CONTENTS	
QTY	COMPONENT
1	mpower Exterior Light Bar built to your specifications

OPTIONAL MOUNTING HARDWARE*	
1	Vehicle Specific Hook Kit / Hardware
2	Fixed Height Mounting Brackets w/ Hardware
3	Flat Mount Hardware Kit
4	Headache Brackets w/ Hardware

OPTIONAL CONTROL EQUIPMENT		
COMPONENTS	Breakout Box LIN (Standard) Qty.	Breakout Box CAN System Qty.
Universal BOB (LIN)	1	0
Universal BOB (CAN)	0	1
24 Pin Harness	1	1
4 Pin Harness	1	1
5 Pin Harness	0	1

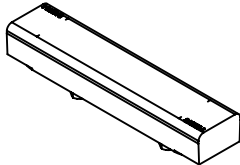
**\*Components and Mounting Hardware will vary with each Lightbar depending on vehicle specified on order form.**

TECHNICAL SPECIFICATIONS			
INPUT VOLTAGE RANGE		9-16 Vdc	
OPERATING TEMPERATURE		-40°C to +65°C (-40°F to +149°F)	
ELECTRICAL PROTECTION		Reverse Polarity, Transient Voltage, Over-Voltage, High-Temperature Thermal Fold-back	
MATERIAL		Top Cover: Aluminum Alloy / LED Modules: Dow Corning Silicone Lens	
WIRING		Power Cable: 15ft, 10AWG Wires, (+) RED, (-) BLACK, Data Line: 22AWG GREEN Power Cable: 25ft, 8AWG Wires, (+) RED, (-) BLACK, Data Line: 22AWG GREEN	
STANDBY CURRENT (Per Module)		IGNITION ON: 0.20 Amps, IGNITION OFF: <8.5 mA	
STANDBY POWER (Per Module)		IGNITION ON: 2.560 Watts, IGNITION OFF: 0.108 Watts	
CURRENT / POWER(Per Module)		CURRENT DRAW	POWER CONSUMPTION
@12Vdc	Flashing	1.14 Amps	14.6 Watts
	Peak	1.9 Amps	24.3 Watts
OVERALL DIMENSIONS	DEPTH	HEIGHT	# OF INBOARDS
48" (48.2" / 122.4 cm)	10.6" (26.9 cm)	1.1" (2.8 cm)	12
55" (54.5" / 138.4 cm)	10.6" (26.9 cm)	1.1" (2.8 cm)	14
	<b>6": 6 &amp; 8 LED Single Color, 12 LED Dual &amp; 18 LED Tri Color Inboard Module</b> INPUT VOLTAGE RANGE: 10-16Vdc CURRENT DRAW: 0.69 Amps @ 12.8 Vdc (Flashing Red) 1.16 Amps @ 12.8 Vdc (Peak Red) 0.87 Amps @ 12.8 Vdc (Flashing Amber, Blue, Green, White) 1.45 Amps @ 12.8 Vdc (Peak Amber, Blue, Green, White) WATTAGE: 4.6W (Red) 7.7W (Amber, Blue, Green, White)		
	<b>3": 4 LED Single Color, 8 LED Single Color, 8 LED Dual Color, 12 LED Tri Color</b> INPUT VOLTAGE RANGE: 10-16Vdc CURRENT DRAW: 0.26 Amps @ 12.8 Vdc (Flashing Red) 0.62 Amps @ 12.8 Vdc (Peak Red) 0.38 Amps @ 12.8 Vdc (Flashing Amber, Blue, Green, White) 0.90 Amps @ 12.8 Vdc (Peak Amber, Blue, Green, White) WATTAGE: 3.3W (Red) 4.9W (Amber, Blue, Green, White)		
CERTIFICATION		APPLICABLE COLORS	
SAE J595 / J845 Class 1		RED, AMBER, BLUE, WHITE	
CALIFORNIA TITLE 13, Class B		RED, AMBER, BLUE	

**FLASHING = AVERAGE  
STEADY ON (100%) = PEAK**

**Unpack Lightbar**

1. Remove light bar from box and packaging.
2. Save packaging for later shipping.
3. Check components/contents.
4. Please reference these instructions for proper wiring and installation.

**Tools Required for Installation**

- 7/16" Socket with ratchet
- Phillips Head Screwdriver
- Drill bit #30
- 5/32 Hex Drive or Allen Wrench

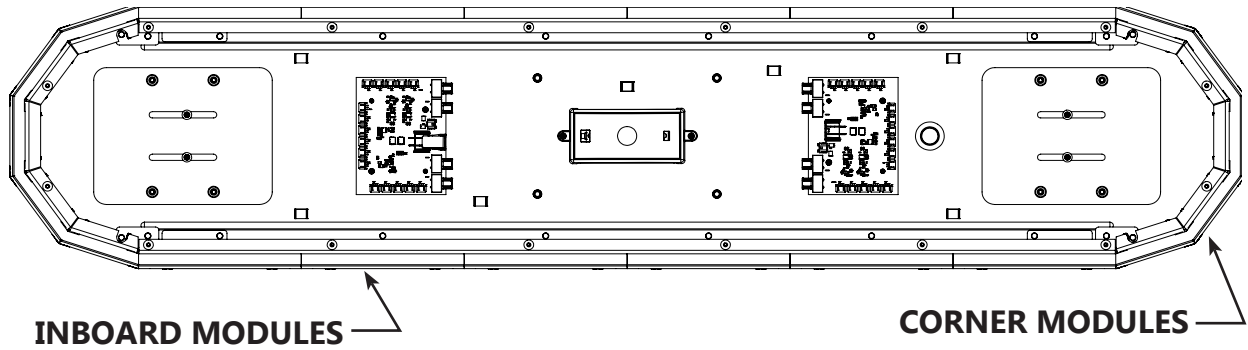
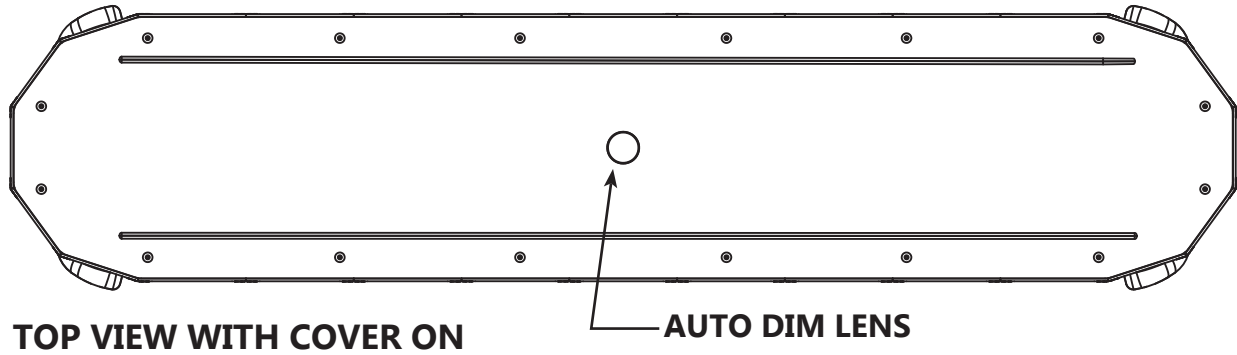

**TOP VIEW WITH COVER OFF\***

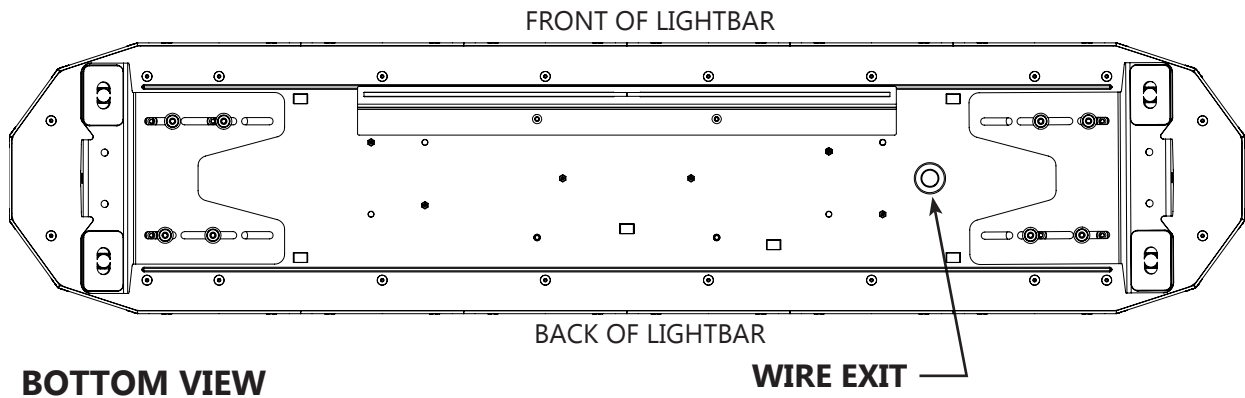

## FIXED HEIGHT BRACKETS AND HOOK MOUNTING (PURSUIT)

1. Attach the supplied screws to the mounting foot to secure the rubber pad as shown in Figure 2. Be sure the torque does not exceed 10 IN-LBS.
2. Insert the 2 plastic washers inside holes of the provided hook brackets.
3. Keeping the lightbar level with the road, attach Mounting Feet to the roof of the vehicle using the 4 supplied bolts. If the lightbar needs to be leveled, a 1.5° wedge can be used (PNFLBWGKT1).
4. Place lightbar centered on the roof, and hold brackets up to the lightbar. A 1/4" to 1/2" gap should be between the hook bracket and front wall of the mounting foot prior to putting any tension on the hook bracket bolt (See Figure 3). Adjust the mounting foot position to accommodate for this gap.
5. Tighten 4 1/4-20 bolts with lock washers to secure the mounting foot to light bar with a max torque between 30-45 inch/lbs with 5/32 hex driver or allen wrench. **DO NOT OVER-TIGHTEN!**
6. Using the holes in the hook bracket as a template, drill 4 holes in the roof using the appropriate size drill. Secure hook bracket to roof with 4 screws on each side.

7. Tighten the hook bracket bolts, torque details below:

Due to different vehicle construction and mounting locations, the torque levels for connecting hooks to the lightbar foot may be different based on the vehicle.

- A. Minimum requirement for torque should be 10 IN/LB, with a maximum level of 45 IN/LB.\*
- B. When installing the bolts connecting the hook to the lightbar foot, monitor both the lightbar and roof of the vehicle.
- C. Tighten to ensure there is no movement of the lightbar or foot by ensuring there is no movement either side to side, or front to rear after the torque has been done.

The lightbar must be securely mounted to the vehicle for safe operation.

\*Deflection of the lightbar and/or the roof of the vehicle may occur when torquing the bolts connecting the hook to the lightbar foot. Any deflection should be kept at a minimum to avoid damage to the lightbar or vehicle.

**NOTE: As always, it is recommended to check the integrity of mounted lightbars on a daily basis to ensure secure attachment to the vehicle for continued safe operation.**

8. Insert the retainer plates over the 2 bolts on each of the hook kit brackets. Screw in the retainer plate to the hook kit bracket using the 8-32 bolts.
9. Install the cover door over the hook bracket bolt to finish the assembly. Place tab of one side into place and then push the second tab into place with a flathead screw driver.

**⚠ WARNING**

Route wires only in locations that are not subjected to potential wear. Make sure to avoid routing wires in the deployment area of your air bag. Refer to your vehicle's owner's manual for airbag deployment zone.

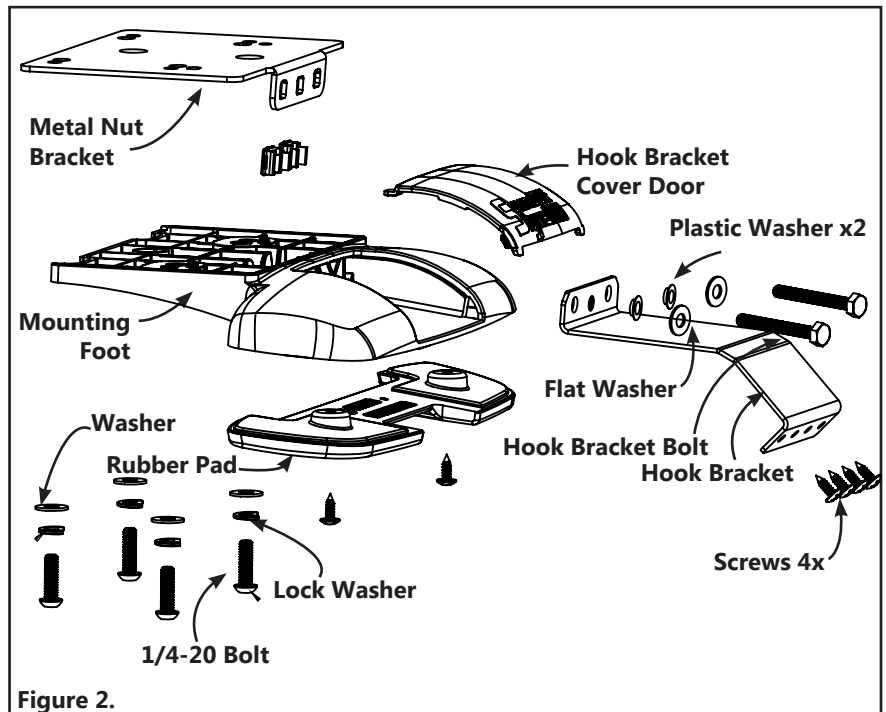
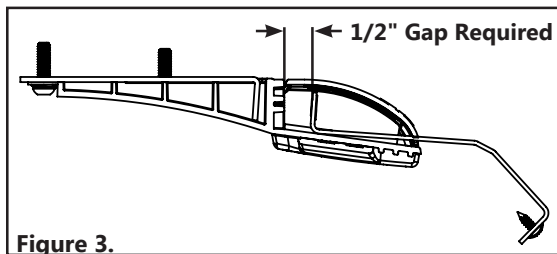
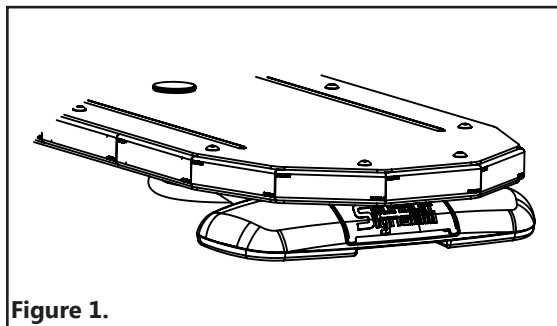

# FIXED HEIGHT BRACKETS AND HOOK MOUNTING (NON-PURSUIT)

1. Attach the supplied screws to the mounting foot to secure the rubber pad as shown in Figure 3. Be sure the torque does not exceed 10 IN-LB.
2. Insert the 1 plastic washer inside holes of the provided hook brackets.
3. Keeping the lightbar level to the road, attach mounting feet to the roof of the vehicle using the 4 supplied bolts.
4. Place lightbar centered on the roof, and hold brackets up to the lightbar. A 1/4" to 1/2" gap should be between the hook bracket and front wall of the mounting foot prior to putting any tension on the hook bracket bolt (See Figure 3). Adjust the mounting foot position to accommodate for this gap.
5. Tighten 4 1/4-20 bolts with lock washers to secure the mounting foot to light bar with a max torque between 30-45 inch/lbs with 5/32 hex driver or allen wrench. **DO NOT OVER-TIGHTEN!**
6. Using the holes in the hook bracket as a template, drill 4 holes in the roof using the appropriate size drill. Secure hook bracket to roof with 4 screws on each side.
7. Due to different vehicle construction and mounting locations, the torque levels for connecting hooks to the lightbar foot may be different based on the vehicle. Minimum requirement for torque should be 10 IN/ LB, with a maximum level of 45 IN/LB. Deflection of the lightbar and/or the roof of the vehicle may occur when torquing the bolts connecting the hook to the lightbar foot. When installing the bolts connecting the hook to the lightbar foot, monitor both the lightbar and roof of the vehicle. Any deflection should be kept at a minimum to avoid damage to the lightbar or vehicle. Tighten to ensure there is no movement of the lightbar or foot by ensuring there is no movement either side to side, or front to rear after the torque has been done. The lightbar must be securely mounted to the vehicle for safe operation. As always, it is recommended to check the integrity of mounted lightbars on a daily basis to ensure secure attachment to the vehicle for continued safe operation.
8. Install the cover door over the hook bracket bolt to finish the assembly. Place tab of one side into place and then push the second tab into place with a flathead screw driver.

**⚠ WARNING**  
Route wires only in locations that are not subjected to potential wear. Make sure to avoid routing wires in the deployment area of your air bag. Refer to your vehicle's owner's manual for airbag deployment zone.

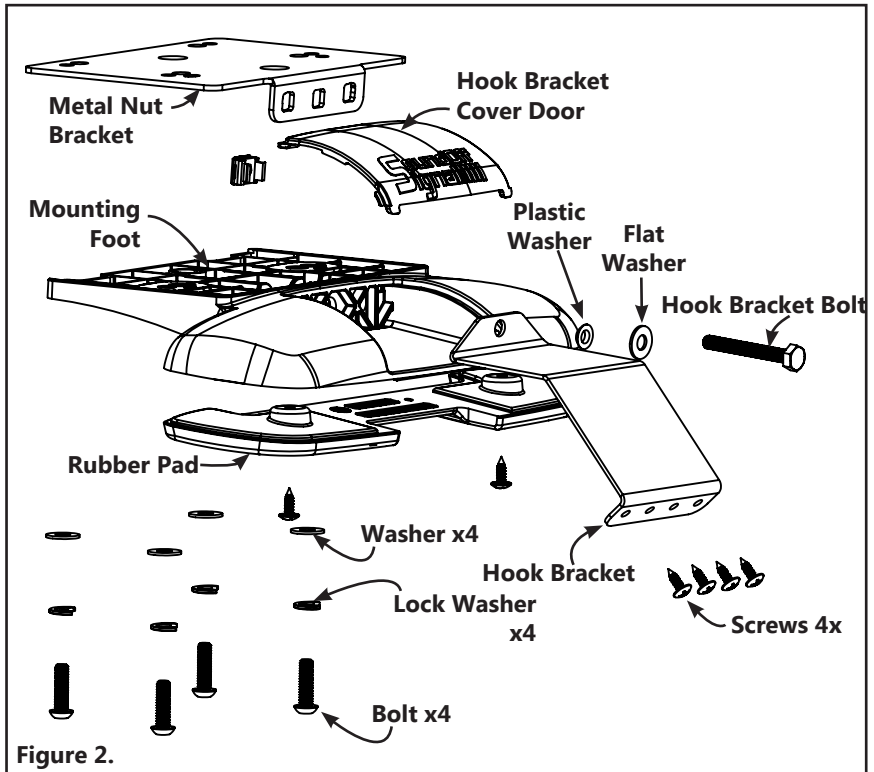
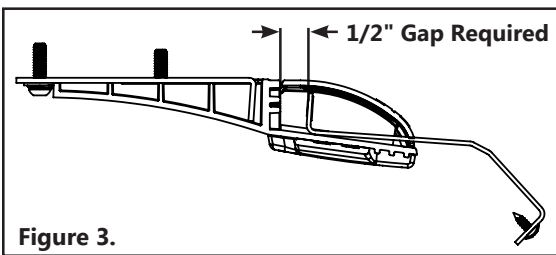
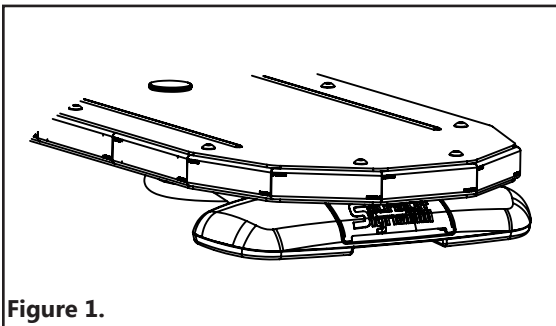

## WIND DEFLECTOR INSTALLATION

1. Cut the "T" gasket (*Item #3*) to an overall length of 20.5" (shown in **Figure 3**).
2. Cut the "T" gasket in half so each part is 10.25" (shown in **Figure 4**).
3. Measure 1/4" from the top of the gasket and 1/2" in from the side (Shown in **Figure 5**). Cut away the small piece of gasket.

 **PRO TIP:** For best fit to the bottom of the lightbar, the bracket should be slightly bent so the outside corners are approximately 1/2" lower than the center of the bracket (shown in **Figure 6**). This allows for best adhesion of the VHB so the corners of the bracket stay tight to the lightbar. The bracket must be adjusted for optimal fit by the installer due to packaging limitations.

4. Install the "T" gasket into the slots on the lower shelf of the wind deflector bracket (*Item #1*) (shown in **Figure 1**).
5. Using the provided surface prep wipe (*Item #6*), clean the entire surface of the wind deflector bracket and the surface of the lightbar where the adhesive tape (*Item #2*) will contact. See "**BOTTOM VIEW**" on page 5 to show front of bar and where to use prep wipe.
6. Cut one piece of adhesive tape in half. Remove one side of the release liner from each half of the adhesive tape and place on the outside edge of the wind deflector bracket. Remove one side of the release liner from the full length adhesive tape center between the outer edge of the bracket and bolt hole and the rear of the upper step (shown in **Figure 7**).
7. The "T" gasket will go towards the front of the lightbar with the adhesive tape towards the bottom of the light bar. Remove the release liner on the tape. Holding the wind deflector bracket above the lightbar, align the bolt holes in the wind deflector bracket with the mounting holes in the mPower lightbar. Stick the bracket to the bottom of the lightbar.
8. Install the provided bolts (*Item #4*) and split lock washer (*Item #5*) to the wind deflector bracket. Tighten bolts until the split lock washer flattens out (shown in **Figure 2**).

CONTAINS		
ITEM #	COMPONENT	QTY
1	WIND DEFLECTOR BRACKET	1
2	ADHESIVE TAPE	2
3	"T" GASKET	1
4	#10-32 SOCKET HEAD BOLT	2
5	#10 SPLIT LOCK WASHER	2
6	SURFACE PREP WIPE	1
7	INSTALLATION INSTRUCTIONS	1

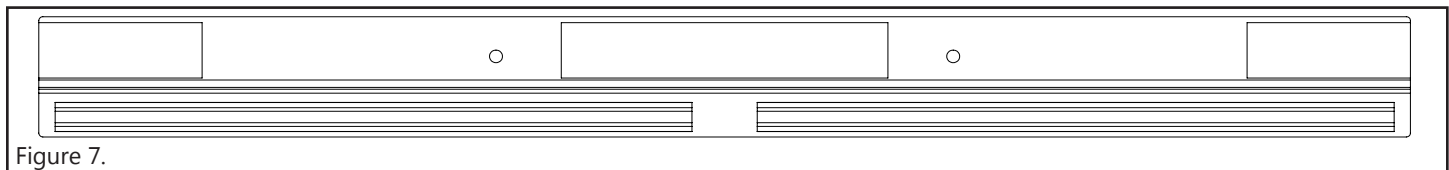
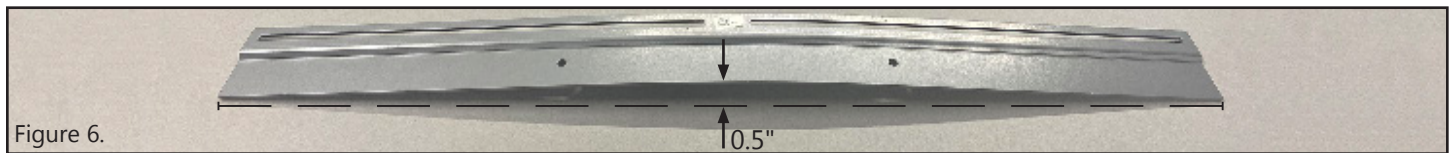
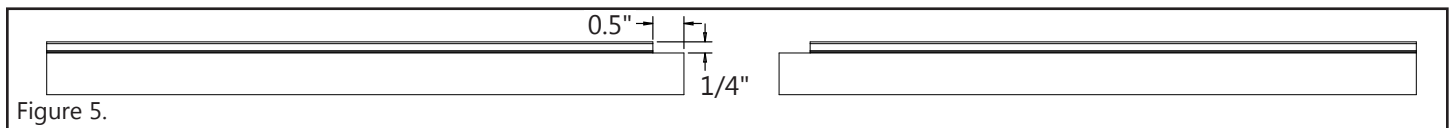
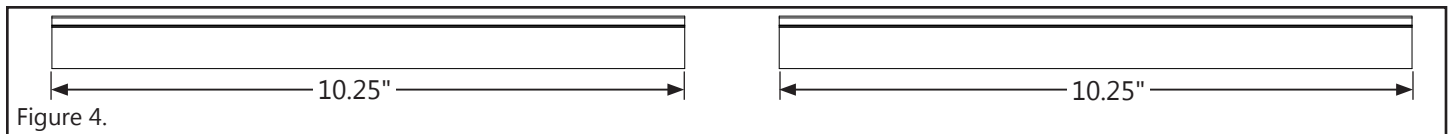
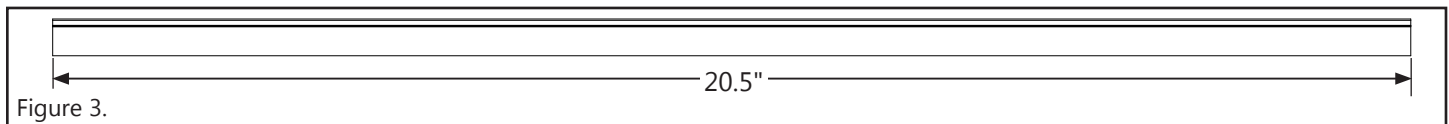
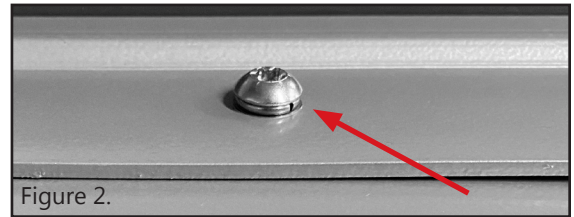
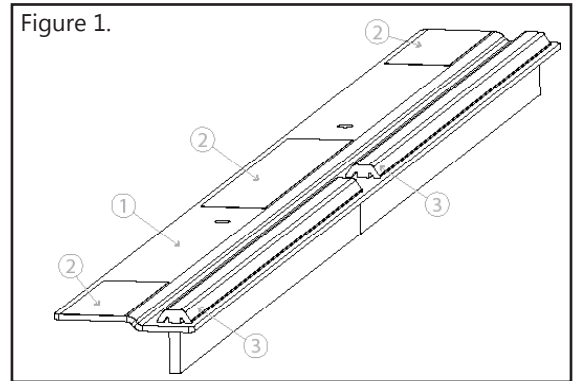



## FUNCTION DEFINITIONS

**Mode Select:** The mPower Exterior Lightbar is equipped with 8 selectable pattern configuration modes. The default input wire configuration allows for 6 modes and an additional 2 modes may be configured with the PC Application using any available input wires. Default is Mode 1 where the Mode select input is floating. Mode 2 is in use when the input is activated. This feature allows up to 8 completely different sets of patterns to be programmed into the Light-bar's non-volatile memory. Once programming configuration is complete, the Mode can be changed "on-the-fly" by an activation switch which applies voltage to the Mode input wire(s).

**Cruise Mode:** Allows the user to program any light group(s) to "Glow" when this feature is activated. The LED intensity is selectable between 1 and 10% duty cycle. For dual / tri color bars, the color for each light group is selectable.

**Takedown Mode:** Allows the user to program any Light Head Group(s) to turn on steady when this feature is activated to provide steady ON takedown lighting.

**Directional Arrow Built-in:** The directional controller is built-in with 11 arrow patterns for each of the 3 modes (left arrow, right arrow, and center out arrow) and the color is selectable for dual / tri color bars

**Steady On Mode:** Accessible with PC App only and allows the user to program any light module to turn on steady at 100% duty cycle.

**Stop / Tail / Turn Mode:** Allows the user to program any Light Head Group(s) to operate in 2 levels of intensity for tail and stop/turn functions.

**Low Power Mode:** Operates lighting at reduced intensity. Selectable between 20 and 90% duty cycle.

**Scene Lighting Mode:** Allows the user to program any Light Head Group(s) to turn on steady when this feature is activated to provide additional scene lighting. The activation of this input also activates the Takedown function

**Speed Sense Input:** The breakout box has a speed sense input that is capable of sensing vehicle speed when connected to the Vehicle Speed Sense (VSS) trigger wire which is supplied in the police upfitter wire harness for some vehicles. This feature is configured using the PC configuration software utility.

**Auto Dimming:** Operates lightbar at reduced intensity when ambient light is low.

**Matrix Input:** Matrix inputs are virtual inputs which can be triggered based on combinations of up to four physical wires or siren input signals. This feature also allows the installer to invert the state of inputs, latch momentary inputs and adjust trigger timing through on and off delay timer settings. This feature is configured using the PC configuration software utility.

## ELECTRICAL INSTALLATION

### Power Cable:

1. Route lightbar power cables as close to vehicles power source (battery) as possible.
2. Install a maximum of 30Amp Fuse (customer supplied) to the end of the RED wire of the Lightbar Power Cable.
  - a. Remove the fuse before connecting any wires to the battery.
  - b. DO NOT USE CIRCUIT BREAKER OR FUSIBLE LINK.
3. Connect the other end of the Fuse to the POSITIVE (+) terminal of the battery.
  - a. Do NOT use any more than 2ft of wire between the battery terminal and the fuse and ensure the wire is protected and secured from being cut into; this is non-fused wire.
4. Connect the BLACK wire to the factory chassis ground right next to the battery.

### Control (Data) Cable:

1. Route Lightbar Control Cable to the location where all controlling equipment will be, i.e. switch box, center console area.
2. Locate the Breakout Box in the same area to connect jumpers from the switching equipment to the breakout box.
3. Refer to breakout box hookup table on page 9.

**NOTE: Breakout Box must be mounted inside vehicle where it will not get wet.**

### Initial Power up Test:

1. Connect the red and the black wire from lightbar to red and black wire of the 4-pin Breakout Box Harness as shown on page 16
2. Connect Green wire from lightbar to green LIN 1 of the 4-pin Breakout Box Harness as shown on page 16.
3. Apply power to pink/white ignition wire on breakout box. See table 1 on page 16.
4. Observe the GREEN Data Link indicator LED on the Breakout Box; the Green LED will be ON showing power is connected.
5. The Red indicator LED on the breakout box will be steady ON whenever any of the input wires are active or data is received from a siren.

### Low Power (Standby) Mode (reduced standby current)

If there is no input to the breakout box the lightbar will go into a "standby" mode. The standby mode is a low power mode that is used to extend the life of your battery. The lightbar will awaken from the standby mode if any input is activated on the breakout box.

### **IMPORTANT**

WHEN PASSING CABLES THROUGH FIREWALL OR OTHER SHEETMETAL, INSERT GROMMET TO PROTECT THE CABLE!



### **WARNING**

Route wires only in locations that are not subjected to potential wear. Make sure to avoid routing wires in the deployment area of your air bag. Refer to your vehicle's owner's manual for airbag deployment zone.



### **WARNING**

ALL CUSTOMER SUPPLIED POWER WIRES CONNECTING TO THE POSITIVE (+) OR NEGATIVE (-) BATTERY TERMINAL OR LOCAL CHASIS GROUND (-) MUST BE SIZED TO SUPPLY AT LEAST 125% OF THE MAXIMUM CURRENT AND PROPERLY FUSED AT THE POWER SOURCE WITH APPROPRIATELY RATED FUSE.

## ELECTRICAL INSTALLATION (CONT.)

### FLASH PATTERNS

\*fpm=Flashes per Minute

\*\*fps=Flashes per Second

#	Name	SAE Compliant Timing	ECE Compliant Timing	California Title 13 Compliant Timing	Color	Sequence	fpm	fps
SC1	Random 1	Yes	No	No	#1	Variable	-	-
SN2	Random 2	No	No	No	#1	Variable	-	-
SC3	Quint	Yes	No	No	#1	Alternating	70	1.2
SC4	Quad 2	Yes	No	No	#1	Variable	-	-
SC5	Q-Switch	Yes	No	No	#1	Variable	-	-
SC6	Double	Yes	No	No	#1	Alternating	115	1.9
SC7	Power Pulse	Yes	No	No	#1	Alternating	180	3
SC8	Road Runner	Yes	No	Yes	#1	Alternating	115	1.9
SC9	Slow Runner	Yes	No	Yes	#1	Alternating	70	1.2
SN10	Warp	No	No	No	#1	Alternating	350	5.8
SN11	Inter-Cycle	No	No	No	#1	Alternating	-	-
SN12	Warp 1-2-3	No	No	No	#1	Alternating	-	-
SC13	E-Single	Yes	Yes	No	#1	Alternating	125	2.1
SC14	E-Double	Yes	Yes	No	#1	Alternating	125	2.1
SC15	E-Triple	Yes	Yes	No	#1	Alternating	125	2.1
SC16	E-Single Sim	Yes	Yes	No	#1	Simultaneous	125	2.1
SC17	E-Double Sim	Yes	Yes	No	#1	Simultaneous	125	2.1
SN18	Super Slow Runner	No	No	No	#1	Alternating	55	0.9
SC19	Quint Simultaneous	Yes	No	No	#1	Simultaneous	70	1.2
SC20	Road Runner Simultaneous	Yes	No	No	#1	Simultaneous	114	1.9
SC21	Quint Pass/Steady Driver	Yes	No	No	#1	-	70	1.2
SC22	Road Runner Pass/Steady Driver	Yes	No	No	#1	-	114	1.9
SC23	Quint 2	Yes	No	No	#1	-	70	1.2
SN24	Warp 2	No	No	No	#1	-	350	5.8
SN25	Inter-Cycle 2	No	No	No	#1	-	-	-
SN26	Flicker Brake	No	No	No	#1	-	-	-
SN27	Flicker Cruise	No	No	No	#1	-	-	-
SN28	Steady	No	No	No	#1	-	-	-
SN29	Manifesto	No	No	No	#1	-	-	-
SN30	Power Evert	No	No	No	#1	-	-	-
SN31	Dazzle	No	No	No	#1	-	-	-
SN32	Quiver	No	No	No	#1	-	-	-

**NOTE: Takedown light patterns are limited to pattern #1 – 25**

## ELECTRICAL INSTALLATION (CONT.)

### FLASH PATTERNS CONT.

\*fpm=Flashes per Minute  
\*\*fps=Flashes per Second

#	Name	SAE Compliant Timing	ECE Compliant Timing	California Title 13 Compliant Timing	Color	Sequence	fpm	fps
SN33	Power Sway	No	No	No	#1	-	-	-
SN34	Evert	No	No	No	#1	-	-	-
SN35	Alternating Rapid Flash	No	No	No	#1	-	-	-
SN36	Swift Impact	No	No	No	#1	-	-	-
SN37	Tango	No	No	No	#1	-	-	-
SN38	Tremble	No	No	No	#1	-	-	-
SN39	Shake	No	No	No	#1	-	-	-
SN40	Evolver	No	No	No	#1	Simultaneous	-	-
SN41	Corner Sweep	No	No	No	#1	-	-	-
SN42	Corner Sweep Slow	No	No	No	#1	-	-	-
SN43	Full/Sweep	No	No	No	#1	-	-	-
SN44	Full/Sweep Slow	No	No	No	#1	-	-	-
SN45	Center Sweep	No	No	No	#1	-	-	-
SN46	Center Sweep Slow	No	No	No	#1	-	-	-
SN47	Orbit	No	No	No	#1	-	-	-
SN48	Orbit Slow	No	No	No	#1	-	-	-
SN49	Double Orbit	No	No	No	#1	-	-	-
SN50	Slow Double Orbit	No	No	No	#1	-	-	-
SN51	Retrograde Orbit	No	No	No	#1	-	-	-
SN52	Slow Retrograde Orbit	No	No	No	#1	-	-	-
SN53	Progressive Alternate	No	No	No	#1	-	-	-
SN54	Recurrent	No	No	No	#1	Simultaneous	-	-
SN55	E-Scroll	No	Yes	No	#1	Alternating	-	-
SN56	ECE-Single - Aura	No	No	No	#1	Alternating	-	-
SN57	ECE-Single - Aura II	No	No	No	#1	Alternating	-	-
DC1	Random Dual #1	Yes	No	No	#1/2	Variable	-	-
DN2	Random Dual #2	No	No	No	#1/2	Variable	-	-
DC3	Quint Dual	Yes	No	No	#1/2	Alternating	70	1.2
DC4	Quad 2 Dual	Yes	No	No	#1/2	Variable	-	-
DC5	Q-Switch Dual	Yes	No	No	#1/2	Variable	-	-
DC6	Double Dual	Yes	No	No	#1/2	Alternating	115	1.9
DC7	Power Pulse Dual	Yes	No	No	#1/2	Alternating	180	3
DC8	Road Runner Dual	Yes	No	Yes	#1/2	Alternating	115	1.9
DC9	Slow Runner Dual	Yes	No	Yes	#1/2	Alternating	70	1.2
DN10	Warp Dual	No	No	No	#1/2	Alternating	350	5.8
DN11	Inter-Cycle Dual	No	No	No	#1/2	Alternating	-	-
DN12	Warp 1-2-3 Dual	No	No	No	#1/2	Alternating	-	-
DN13	Pattern #1 Dual	No	No	No	#1/2	Variable	-	-
DN14	Pattern #2 Dual	No	No	No	#1/2	Variable	-	-

## ELECTRICAL INSTALLATION (CONT.)

### FLASH PATTERNS CONT.

\*fpm=Flashes per Minute  
\*\*fps=Flashes per Second

#	Name	SAE Compliant Timing	ECE Compliant Timing	California Title 13 Compliant Timing	Color	Sequence	fpm	fps
DN15	Impact Dual	No	No	No	#1/2	Variable	-	-
DN16	Explosion Dual	No	No	No	#1/2	Variable	-	-
DC17	Quint Simultaneous Dual	Yes	No	No	#1/2	Simultaneous	70	1.2
DC18	Road Runner Sim. Dual	Yes	No	No	#1/2	Simultaneous	114	1.9
DC19	Quint 2 Dual	Yes	No	No	#1/2	-	70	1.2
DN20	Warp 2 Dual	No	No	No	#1/2	-	350	5.8
DN21	Inter-Cycle 2 Dual	No	No	No	#1/2	-	-	-
DN22	Super Slow Runner Dual	No	No	No	#1/2	-	-	-
DN23	Flicker Cruise Dual	No	No	No	#1/2	-	-	-
DN24	Manifesto Dual	No	No	No	#1/2	-	-	-
DN25	Power Evert Dual	No	No	No	#1/2	-	-	-
DN26	Dazzle Dual	No	No	No	#1/2	-	-	-
DN27	Quiver Dual	No	No	No	#1/2	-	-	-
DN28	Power Sway Dual	No	No	No	#1/2	-	-	-
DN29	Evert Dual	No	No	No	#1/2	-	-	-
DN30	Alternating Rapid Flash Dual	No	No	No	#1/2	-	-	-
DN31	Swift Impact Dual	No	No	No	#1/2	-	-	-
DN32	Tango Dual	No	No	No	#1/2	-	-	-
DN33	Tremble Dual	No	No	No	#1/2	-	-	-
DN34	Shake Dual	No	No	No	#1/2	-	-	-
DN35	Evolver Dual	No	No	No	#1/2	Simultaneous	-	-
DN36	Corner Sweep Dual	No	No	No	#1/2	-	-	-
DN37	Corner Sweep Slow Dual	No	No	No	#1/2	-	-	-
DN38	Full/Sweep Dual	No	No	No	#1/2	-	-	-
DN39	Full/Sweep Slow Dual	No	No	No	#1/2	-	-	-
DN40	Center Sweep Dual	No	No	No	#1/2	-	-	-
DN41	Center Sweep Slow Dual	No	No	No	#1/2	-	-	-
DN42	Orbit Dual	No	No	No	#1/2	-	-	-
DN43	Orbit Slow Dual	No	No	No	#1/2	-	-	-
DN44	Double Orbit Dual	No	No	No	#1/2	-	-	-
DN45	Slow Double Orbit Dual	No	No	No	#1/2	-	-	-
DN46	Retrograde Orbit Dual	No	No	No	#1/2	-	-	-
DN47	Slow Retrograde Orbit Dual	No	No	No	#1/2	-	-	-
DN48	Progressive Alternate Dual	No	No	No	#1/2	-	-	-
DN49	Recurrent Dual		No	No	#1/2	Simultaneous	-	-
DN50	E-Scroll Dual	No	Yes	No	#1/2	Alternating	-	-
DN51	Road Runner Dual - Aura	No	No	No	#1/2	Alternating	-	-
DN52	Road Runner Dual - Aura II	No	No	No	#1/2	Alternating	-	-
DN53	Slow Runner Dual - Aura	No	No	No	#1/2	Alternating	-	-

## ELECTRICAL INSTALLATION (CONT.)

### FLASH PATTERNS CONT.

\*fpm=Flashes per Minute

\*\*fps=Flashes per Second

#	Name	SAE Compliant Timing	ECE Compliant Timing	California Title 13 Compliant Timing	Color	Sequence	fpm	fps
DN54	Slow Runner Dual - Aura II	No	No	No	#1/2	Alternating	-	-
DN55	Super Slow Runner Dual - Aura	No	No	No	#1/2	Alternating	-	-
DN56	Super Slow Runner Dual - Aura II	No	No	No	#1/2	Alternating	-	-
DN57	Corner Sweep Slow Dual - Aura	No	No	No	#1/2	-	-	-
DN58	Full Sweep Slow Dual - Aura	No	No	No	#1/2	-	-	-
DN59	Center Sweep Slow Dual - Aura	No	No	No	#1/2	-	-	-
DN60	Orbit Slow Dual - Aura	No	No	No	#1/2	-	-	-
DN61	Double Orbit Slow Dual - Aura	No	No	No	#1/2	-	-	-
DN62	Retrograde Orbit Slow Dual - Aura	No	No	No	#1/2	-	-	-
DN63	Flicker Cruise alternate Dual - Aura	No	No	No	#1/2	-	-	-
TN1	Pattern 1 Tri	No	No	No	#1/2/3	Alternating	-	-
TN2	Random Tri	No	No	No	#1/2/3	Alternating	-	-
TC3	Quint Tri	Yes	No	No	#1/2/3	Alternating	70	1.2
TC4	Quad 2 Tri	Yes	No	No	#1/2/3	Alternating	-	-
TN5	Pattern 2 Tri	No	No	No	#1/2/3	-	-	-
TC6	Double Tri	Yes	No	No	#1/2/3	Alternating	115	1.9
TC7	Power Pulse Tri	Yes	No	No	#1/2/3	Alternating	180	3
TC8	Road Runner Tri	Yes	No	Yes	#1/2/3	Alternating	115	1.9
TC9	Slow Runner Tri	Yes	No	Yes	#1/2/3	Alternating	70	1.2
TN10	Warp Tri	No	No	No	#1/2/3	Alternating	350	5.8
TN11	Inter-Cycle Tri	No	No	No	#1/2/3	Alternating	-	-
TN12	Warp 1-2-3 Tri	No	No	No	#1/2/3	Alternating	-	-
TN13	Super Slow Runner Tri	No	No	No	#1/2/3	Alternating	55	0.9
TC14	Quint Simultaneous Tri	Yes	No	No	#1/2/3	Simultaneous	70	1.2
TC15	Road Runner Sim. Tri	Yes	No	No	#1/2/3	Simultaneous	114	1.9
TC16	Quint 2 Tri	Yes	No	No	#1/2/3	Alternating	70	1.2
TN17	Warp 2 Tri	No	No	No	#1/2/3	Alternating	350	5.8
TN18	Inter-Cycle 2 Tri	No	No	No	#1/2/3	Alternating	-	-
TN19	Pattern 3 Tri	No	No	No	#1/2/3	-	-	-
TN20	Flicker Cruise Tri	No	No	No	#1/2/3	-	-	-
TN21	Manifesto Tri	No	No	No	#1/2/3	-	-	-
TN22	Power Evert Tri	No	No	No	#1/2/3	-	-	-
TN23	Dazzle Tri	No	No	No	#1/2/3	-	-	-
TN24	Quiver Tri	No	No	No	#1/2/3	-	-	-
TN25	Power Sway Tri	No	No	No	#1/2/3	-	-	-
TN26	Evert Tri	No	No	No	#1/2/3	-	-	-
TN27	Alternating Rapid Flash Tri	No	No	No	#1/2/3	-	-	-
TN28	Swift Impact Tri	No	No	No	#1/2/3	-	-	-
TN29	Tango Tri	No	No	No	#1/2/3	-	-	-

## ELECTRICAL INSTALLATION (CONT.)

### FLASH PATTERNS CONT.

\*fpm=Flashes per Minute  
\*\*fps=Flashes per Second

#	Name	SAE Compliant Timing	ECE Compliant Timing	California Title 13 Compliant Timing	Color	Sequence	fpm	fps
TN30	Tremble Tri	No	No	No	#1/2/3	-	-	-
TN31	Shake Tri	No	No	No	#1/2/3	-	-	-
TN32	Evolver Tri	No	No	No	#1/2/3	Simultaneous	-	-
TN33	Corner Sweep Tri	No	No	No	#1/2/3	-	-	-
TN34	Corner Sweep Slow Tri	No	No	No	#1/2/3	-	-	-
TN35	Full/Sweep Tri	No	No	No	#1/2/3	-	-	-
TN36	Full/Sweep Slow Tri	No	No	No	#1/2/3	-	-	-
TN37	Center Sweep Tri	No	No	No	#1/2/3	-	-	-
TN38	Center Sweep Slow Tri	No	No	No	#1/2/3	-	-	-
TN39	Orbit Tri	No	No	No	#1/2/3	-	-	-
TN40	Orbit Slow Tri	No	No	No	#1/2/3	-	-	-
TN41	Double Orbit Tri	No	No	No	#1/2/3	-	-	-
TN42	Double Orbit Slow Tri	No	No	No	#1/2/3	-	-	-
TN43	Retrograde Orbit Tri	No	No	No	#1/2/3	-	-	-
TN44	Retrograde Orbit Slow Tri	No	No	No	#1/2/3	-	-	-
TN45	Progressive Alternate Tri	No	No	No	#1/2/3	-	-	-
TN46	Recurrent Tri	No	No	No	#1/2/3	Simultaneous	-	-
TN47	E-Scroll Tri	No	Yes	No	#1/2/3	Alternating	-	-
TN48	Road Runner Tri - Aura	No	No	No	#1/2/3	Alternating	-	-
TN49	Road Runner Tri - Aura II	No	No	No	#1/2/3	Alternating	-	-
TN50	Slow Runner Tri - Aura	No	No	No	#1/2/3	Alternating	-	-
TN51	Slow Runner Tri - Aura II	No	No	No	#1/2/3	Alternating	-	-
TN52	Super Slow Runner Tri - Aura	No	No	No	#1/2/3	Alternating	-	-
TN53	Super Slow Runner Tri - Aura II	No	No	No	#1/2/3	Alternating	-	-
TN54	Corner Sweep Slow Tri - Aura	No	No	No	#1/2/3	-	-	-
TN55	Full Sweep Slow Tri - Aura	No	No	No	#1/2/3	-	-	-
TN56	Center Sweep Slow Tri - Aura	No	No	No	#1/2/3	-	-	-
TN57	Orbit Slow Tri - Aura	No	No	No	#1/2/3	-	-	-
TN58	Double Orbit Slow Tri - Aura	No	No	No	#1/2/3	-	-	-
TN59	Retrograde Orbit Slow Tri - Aura	No	No	No	#1/2/3	-	-	-

## ELECTRICAL INSTALLATION (CONT.)

### ARROW PATTERNS

#	Name	SAE Compliant Timing	ECE Compliant Timing	California Title 13 Compliant Timing	Color	Sequence	fpm	fps
1	Single Fast	No	No	No	#1	-	-	-
2	Single Slow	No	No	No	#1	-	-	-
3	Chaser Fast	No	No	No	#1	-	-	-
4	Chaser Slow	No	No	No	#1	-	-	-
5	Fill Fast	No	No	No	#1	-	-	-
6	Fill Slow	No	No	No	#1	-	-	-
7	Grow/Shrink	No	No	No	#1	-	-	-
8	Warning w/Arrow	No	No	No	#1	-	-	-
9	Warning w/Arrow Fill	No	No	No	#1	-	-	-
10	Arrow Random 1	No	No	No	#1	-	-	-
11	Arrow Random 2	No	No	No	#1	-	-	-
12	Grow/Shrink 2	No	No	No	#1	-	-	-
13	Single Slow - Aura III	No	No	No	#1	-	-	-
14	Fill Slow - Aura III	No	No	No	#1	-	-	-



# ELECTRICAL INSTALLATION (CONT.)

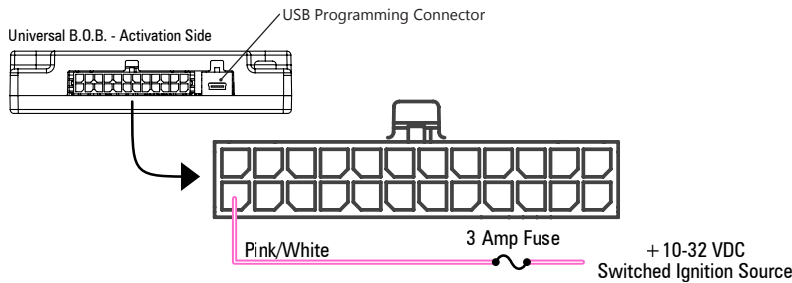
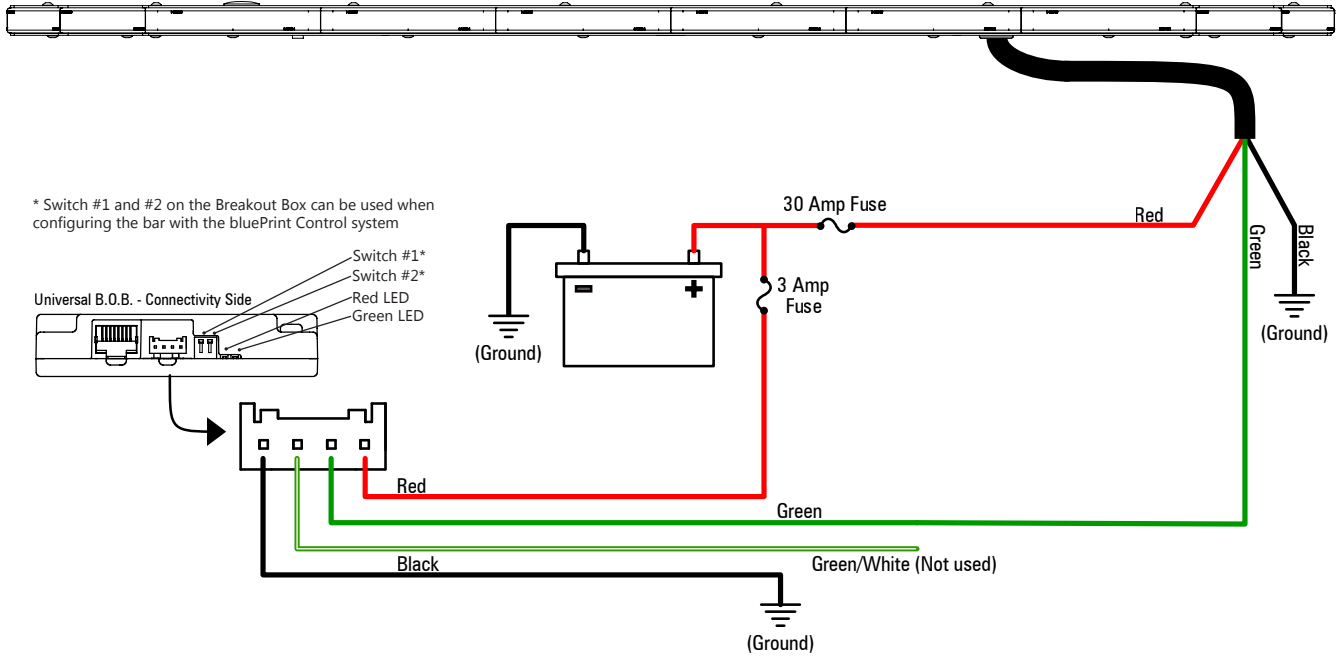

**Universal Breakout Box Setting I.D.**

\*Only used with bluePRINT applications with more than 1 Universal Breakout Box.

	<b>ID 1</b>	1 - Up/Off 2 - Up/Off		<b>ID 3</b>	1 - Down/On 2 - Up/Off
	<b>ID 2</b>	1 - Up/Off 2 - Down/On		<b>ID 4</b>	1 - Down/On 2 - Down/On

**Functional Inputs**

Functional Inputs connect to your control head or switching unit. Applying +10-32Vdc to any functional Input will activate it's function (default-active high).

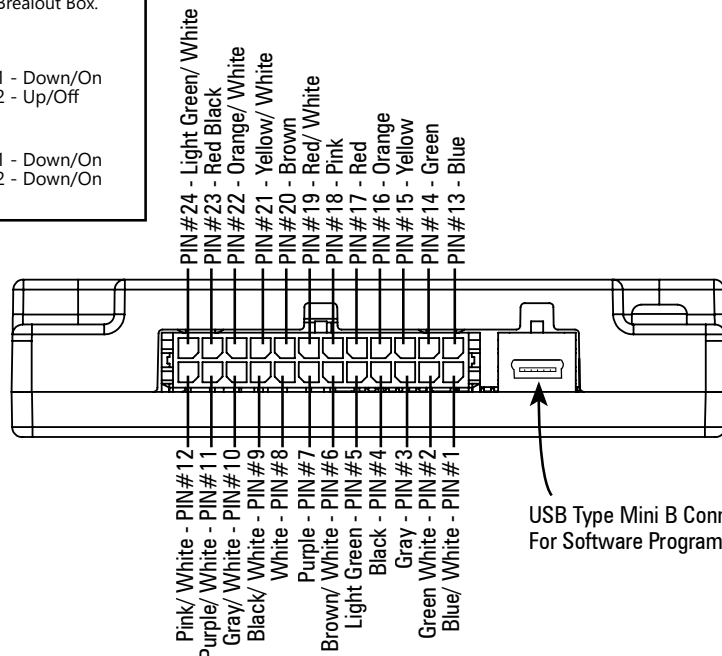

# WIRE FUNCTION DEFAULTS

Table 1

Wire Pin #	Wire Color	Wire Function	Mods affected	Color (→: If the color is not populated, it would be the next color listed)	Flash	CERT chosen	
						SAE/None	ECE
						Pattern	
1	BLU/WHT	Cruise 1	Inboard 1, Corners & Alleys (Front and Rear)	Color 1, not White	-	-	-
2	GRN/WHT	Warning	Entire Bar (Rear)	Color 1	Mode 2	Slow Runner	ECE Single
3	GRY	STT - Rear Turn - Left	Inboard 2 (pair)	Amber→Red→nothing	-	-	-
4	BLK	STT - Rear Turn - Right	Inboard 2 (pair)	Amber→Red→nothing	-	-	-
5	LTGRN	STT - Tail	Inboard 2 (pair)	Red→nothing	-	-	-
6	BRN/WHT	Disable	Left Side Endcap	-	-	-	-
7	PUR	Disable	Right Side Endcap	-	-	-	-
8	WHT	Unassigned	-	-	-	-	-
9	BLK/WHT	Low Power 1	all	-	-	-	-
10	GRY/WHT	Left Arrow	Inboards (Rear)	Amber→Color 1	-	-	-
11	PUR/WHT	Right Arrow	Inboards (Rear)	Amber→Color 1	-	-	-
12	PNK/WHT	IGNITION	-	-	-	-	-
13	BLU	Warning	Entire Bar (Front and Rear)	Color 1	Mode 1	Flicker Cruise	ECE Single
14	GRN	Warning	Entire Bar (Front)	Color 1	Mode 2	Slow Runner	ECE Single
15	YEL	Warning	Entire Bar (Front and Rear)	Color 1	Mode 3	Quint	ECE Single
16	ORG	Warning	Entire Bar (Front and Rear)	Color 1	Mode 4	Intercycle	ECE Single
17	RED	Warning	Entire Bar (Front and Rear)	Color 1	Mode 5	Warp	ECE Single
18	PNK	Warning with Cruise 1 behind	Entire Bar (Front and Rear)	Color 1	Mode 6	Super Slow Runner	ECE Single
19	RED/WHT	Flashing	Takedown	White→nothing	-	-	-
20	BRN	Scene	Left Alley and Left Alley Scene	White→nothing	-	-	-
21	YEL/WHT	Scene	Right Alley and Right Alley Scene	White→nothing	-	-	-
22	ORG/WHT	Takedown	Selected at Bar Creation	White	-	-	-
23	RED/BLK	Scene 1	Selected at Bar Creation	White	-	-	-
24	LTGRN/WHT	VSS Input for Speed 1 and 2	-	-	-	-	-

**BREAKOUT BOX INSTRUCTIONS:  
(LIN COMMUNICATION)**

- Securely snap in the 4-pin and 24-pin connectors
- Install a 3Amp Fuse (customer supplied) to the end of the Red wire of the 4-pin connector harness.
- Hook up power, ground, and LIN to the corresponding wire on the 4-pin connector harness. (Table 2)
- Refer to Table 1 for the input wire's default function
- Follow the label for the wire color to connect to a +10-32Vdc source, which turns on that given light or lights
- Make sure your wire connections are secured and isolated from any other wire

**4-PIN CONNECTOR HARNESS**

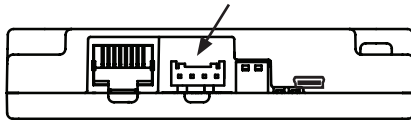

Table 2

Wire Pin	Color	Function
1	Black	Ground
2	Green/White	LIN 2 - not used with this lightbar
3	Green	LIN 1 - mPower Lightbar Operation
4	Red	Power



TO CHANGE WIRE FUNCTIONS FOR CUSTOM APPLICATIONS PLEASE SCAN QR CODE FOR LINK FOR SOUNDOFF CENTRAL LIGHTBAR SOFTWARE GUIDES.

**CAN BREAKOUT BOX INSTRUCTIONS:  
(CAN COMMUNICATION)**

- Securely snap in the 4-pin, 5-pin and 24-pin connectors
- Refer to Table 1 for the input wire default functions and to Table 3 for the CAN wire functions
- Install a 3Amp Fuse (customer supplied) to the end of the Red wire of the 4-pin connector harness. (Table 2)
- Hook up power, ground, and LIN to the corresponding wire on the 4-pin connector harness. (Table 2)
- Follow the label for the wire color to connect to a 10-32 Vdc source, which turns on that given light or lights
- Make sure your wire connections are secured and isolated from any other wire
- If extending the 5-pin connector harness, a shielding wire running the length of the entire harness may be necessary

**CONNECTOR PRESENT WITH CAN BOB**

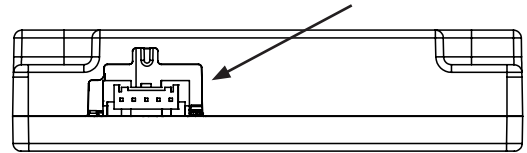
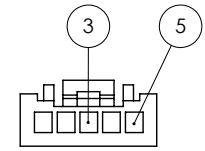

Table 3

Wire Pin	Color	Function
3	Green	CAN Low
5	Yellow	CAN High



CAN CONNECTOR

## CONNECTION OF LIGHTBAR BREAKOUT BOX TO SOUNDOFF SIGNAL SIREN:

Note: Requires PC configuration app to map siren control switches to lightbar functions. Plug 1 end of RJ-45 cable to available jack on siren amplifier.

### ETSA481CSR or ETSA482CSR

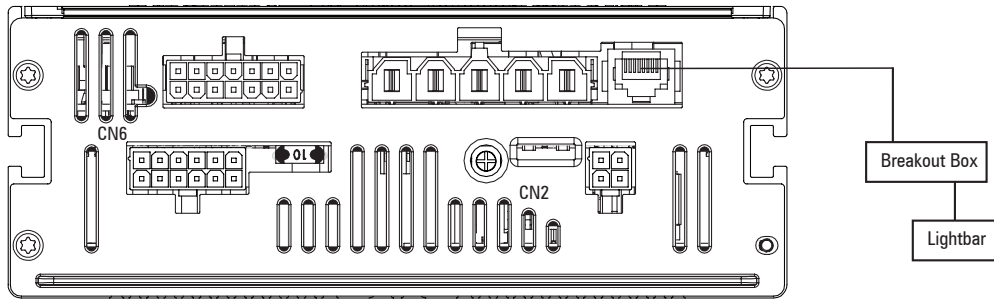

### ETSA481RSP, ETSA482RSP, ETSA461HPP, ETSA462HPP

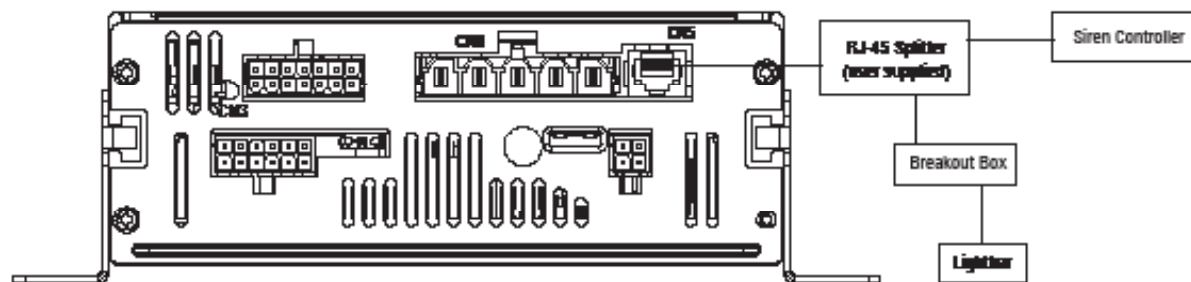

### ETSA5100/5200

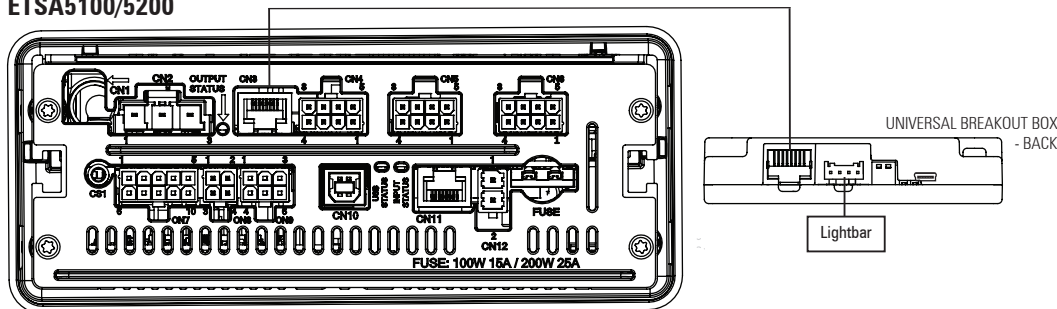

### SoundOff Central® Software Universal Breakout Box ID Settings

When using more than one lightbar universal breakout box (UBOB) with SoundOff Central Software, set the ID number for each UBOB using the dip switches and then configure the light bars accordingly in the Software.

ID	1	2	3	4
1 - Up/Off	1 - Up/Off	1 - Up/Off	1 - Down/On	1 - Down/On
2 - Up/Off	2 - Up/Off	2 - Down/On	2 - Up/Off	2 - Down/On

1. Select Lightbars Tab on the main SETUP Page.

2. Under Lightbars tab, select the EXTERNAL tab to see UBOB list. The number after the UBOB is the ID needed.

3. Hover cursor over the (?) to open up Universal Breakout Box ID Information.

## SIREN FUNCTIONS

#	Button	Function	Mods affected	"Color (if the color is not populated, it would be the next color listed)"	Flash	CERT chosen	
						SAE/NONE	ECE
						Pattern	
S1	Pushbutton 1	Left Arrow	Inboards	Amber→Color 1	-	-	-
S2	Pushbutton 2	Scene	Left Alley and Left Alley Scene	White→nothing	-	-	-
S3	Pushbutton 3	Scene	Right Alley and Right Alley Scene	White→nothing	-	-	-
S4	Pushbutton 4	Takedown	Selected at Bar Creation	White	-	-	-
S5	Pushbutton 5	Cruise 1	Inboard 1, Corners & Alleys (Front and Rear)	Color 1	-	-	-
S6	Pushbutton 6	Low Power 1	Entire Bar	-	-	-	-
S7	Pushbutton 7	Scene 1	Selected at Bar Creation	White	-	-	-
S8	Pushbutton 8	-		No	-	-	-
S9	Single Button Arrow	Right Arrow	Inboards	Amber→Color 1	-	-	-
S10	Slide Switch 1	Warning	Entire bar (Rear)	Color 1	Mode 2	Slow Runner	ECE Single
S11	Slide Switch 2	Warning	Entire Bar (Front and Rear)	Color 1	Mode 3	Quint	ECE Single
S12	Slide Switch 3	Warning	Entire Bar (Front and Rear)	Color 1	Mode 4	Intercycle	ECE Single

## PHOTO SENSOR

The photo sensor continuously monitors ambient light conditions and will control functions configured for operation with the photo sensor input. By default, the photo sensor will set all light modules into low power mode when dark ambient light levels below 50 lux are detected for more than 5 seconds. When ambient light levels exceed 300 lux for 5 seconds, the low power mode will clear/turn off and the lightbar will revert back to full intensity.

The photo sensor is subject to ambient light conditions of the specific environment for the vehicle and needs to be thoroughly tested by the installer to ensure proper light levels and delay are selected to provide the most effective operation in different lighting conditions.

The photo sensor detects ambient light levels, so parking the vehicle under a bright street light during night-time use may (CLEAR) turn off the photo sensor input. Likewise, driving through a dark tunnel during daytime use may (SET) the photo sensor input. Ensure the operator of the vehicle is aware of such possible conditions and provide additional controls to the breakout box to allow the operator the ability to manually over-ride the functions when required.

The photo sensor is located in the middle of the AutoDim / Mod ID module.

Changing the ambient light SET/CLEAR levels may be modified by updating the setting in the 'Photo Sensor' tab in the PC Application.

The photo sensor controls may be updated by using the PC App. Refer to the PC App instructions for more detail.

# LED MODULE REPLACEMENT

## LED Module Replacement:

1. Remove top cover by removing screws.
2. Disconnect the harness of the module in question from the driver board.
3. Remove the entire light module being replaced.
4. Replacement modules should be connected to the mpower Connector port on the AutoDim / Mod ID module.
5. Once the module is connected, the LED's under the 10's and 1's labels on the AutoDim / Mod ID module will flash Green to indicate to the module's ID number.

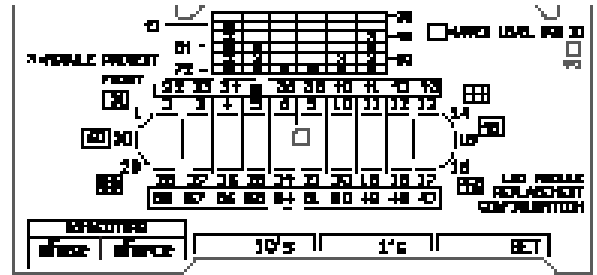

AUTODIM / MOD ID MODULE

**EXAMPLE: An ID of 20 will flash only the 10's LED twice. Similarly an ID of 2 will flash only the 1's LED twice. An ID of 15 would flash the 10's LED once then the 1's LED 5 times.**

6. To configure a new ID, quick press the 10's button to add 10 to the current ID and/or press the 1's button to add 1 to the current ID. Pressing and holding the 10's or 1's button until the corresponding red LED goes off will subtract 10 or 1 respectively. Pressing and holding both the 10's and 1's buttons at the same time and releasing once the red LED's turn off will change the ID to 1.
7. Once the 10's or 1's buttons have been pressed the LED's on the AutoDim / Mod ID module will change from green to red and flash the potential new ID. If the ID flashes correctly press the SET button and it will configure the module to that ID. The LED's on the AutoDim / Mod ID module will now flash the module's new ID in green. If the new module ID flashes in green correctly then the module is ready to be connected to the bar.

**EXAMPLE: If your module started out with ID 15 and the desired ID was 30 you would press the 10's button once and the 1's button 5 times(15 + 15 = 30.) Verify the 10's LED flashes red 3 times(indicating ID 30) then press the SET button. After the SET button is pressed the 10's LED should flash green 3 times.**

**NOTE: The highest available ID is 60. Going past 60 will start back at 1 and going backwards from 1 will go to 60.**

8. Replace the top cover and use the replacement screws that are included with the replacement module.

## MODULE LOCATION ID'S

48" LIGHTBAR

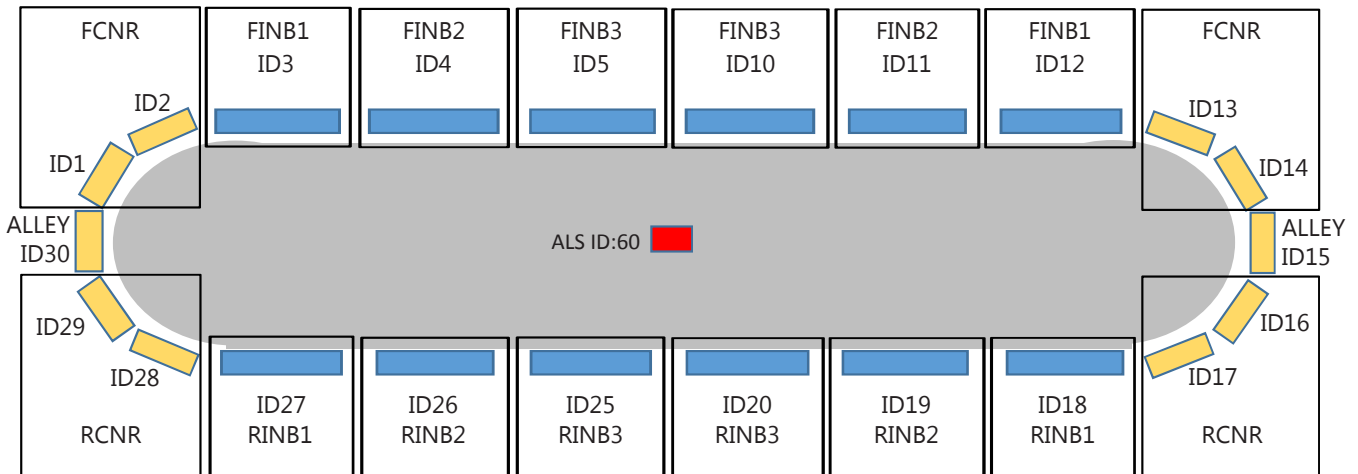

55" LIGHTBAR

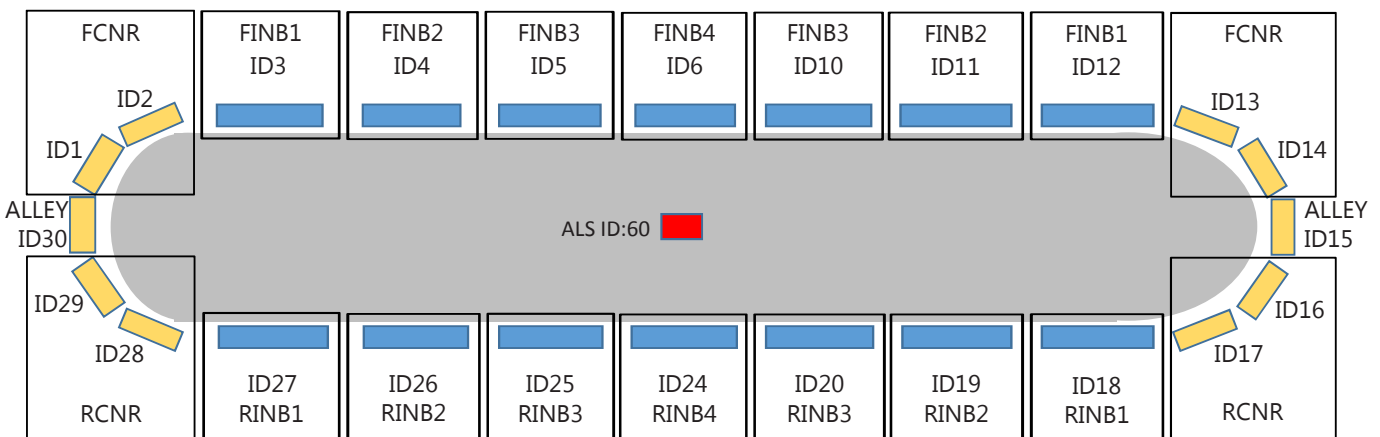

# REPLACEMENT PARTS & ACCESSORIES

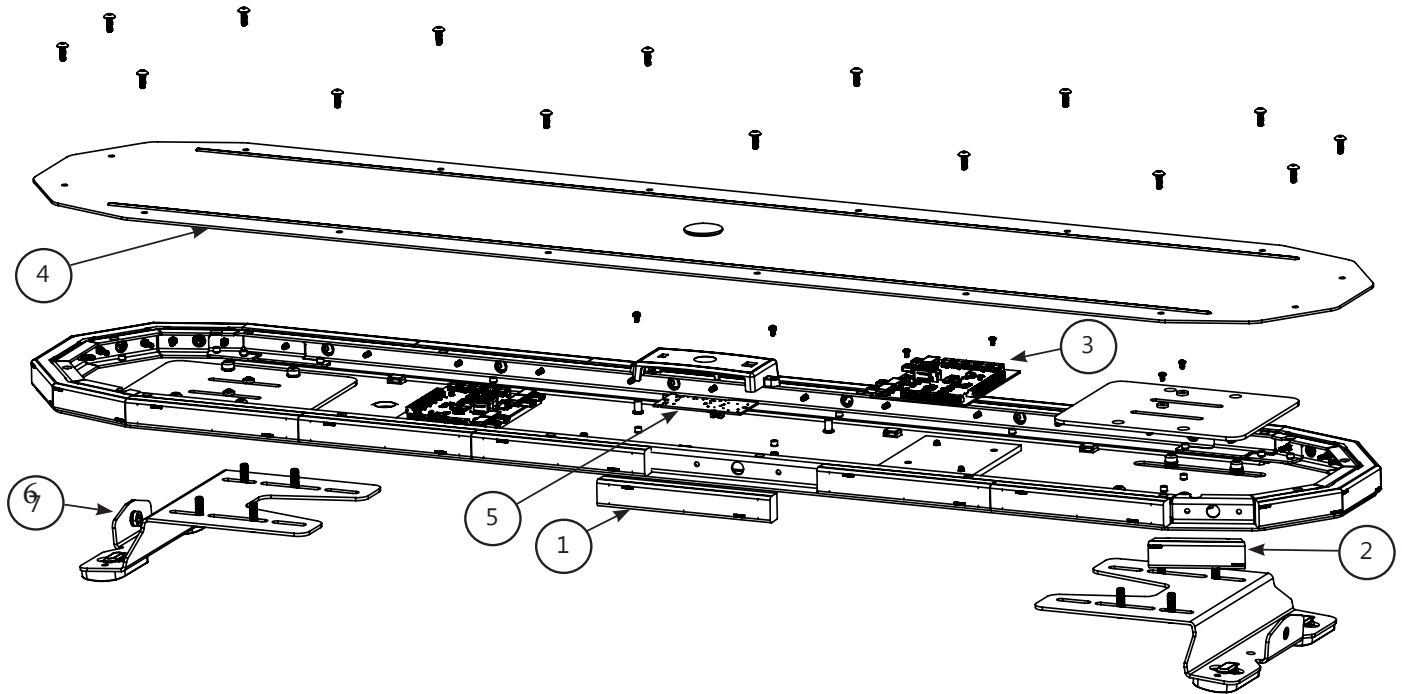

ITEM #	PART#	DESCRIPTION
2	PMPLBCSS204(x)C	4 LED SINGLE COLOR 3" CORNER MODULE (SAE)
2	PMPLBCSS208(x)C	8 LED SINGLE COLOR 3" CORNER MODULE (SAE)
2	PMPLBCES208(x)C	8 LED SINGLE COLOR 3" CORNER MODULE (ECE)
2	PMPLBCSD208(x)C	8 LED DUAL COLOR 3" CORNER MODULE (SAE)
2	PMPLBCST212(XXX)C	12 LED TRI COLOR 3" CORNER MODULE (SAE)
1	PMPLBLLS206(x)C	6 LED SINGLE COLOR 6" INBOARD MODULE
1	PMPLBLLS208(x)C	8 LED SINGLE COLOR 6" INBOARD MODULE
1	PMPLBLLD212(x)C	12 LED DUAL COLOR 6" INBOARD MODULE
1	PMPLBLLT218(XXX)C	18 LED TRI COLOR 6" INBOARD MODULE
3	PMPLBDRV3	MPOWER LB DISTRIBUTION BOARD
5	PMPLBDAD1	MPOWER LB ALS/MOD BOARD
	PMPLBHNPW2	POWER HARNESS (15FT)
	PMPLBHNPW3	POWER HARNESS (25FT)
	PUVBBJ00	UNIVERSAL BREAKOUT BOX - STANDARD LIN COMMUNICATION
	PUVBBJC1	UNIVERSAL BREAKOUT BOB - CAN COMMUNICATION
	PUVBBHNCN1	CAN BREAKOUT BOX 5-PIN HARNESS
	PUVBBHNPW1	BREAKOUT BOX 4-PIN HARNESS
	PEPL9BBHN(x)	BREAKOUT BOX 24-PIN HARNESS
4	PMPLBTSL48	MPOWER LB 48" TOP COVER 6" (SILVER)
4	PMPLBTSL55	MPOWER LB 55" TOP COVER 6" (SILVER)
	PMPLBK00	STANDARD FIXED HEIGHT MOUNT w/THICK & THIN PADS
	PMPLBK01	STANDARD FIXED HEIGHT MOUNT w/THICK PADS
	PMPLBK02	STANDARD FIXED HEIGHT MOUNT w/THIN PADS
	PMPLBK03	CLASSIC FIXED HEIGHT MOUNT
	PMPLBK04	EXTRA LOW FIXED HEIGHT MOUNT
	PMPLBK05	XtraFit UNIVERSAL MOUNT
	PMPLBK06	HEADACHE RACK MOUNT
6	PMPLBK09	SLIDING FIXED MOUNT
	PMPLBDFL2S	WIND NOISE DEFLECTOR KIT

# MPOWER LIGHT BAR TROUBLESHOOTING

## Normal Operation

Under Normal operation with ignition input powered, the breakout box will have the Green LED ON and the Red LED light will be ON whenever an input is active and both switches are in the UP (off) position.

GENERAL TROUBLESHOOTING	
Before further troubleshooting steps, start here:	<ul style="list-style-type: none"> <li>• Check power source to the lightbar and breakout box (10AWG red and 22AWG red wires).</li> <li>• Check the ground source to the lightbar and breakout box (10AWG black and 22AWG black wires).</li> <li>• Check ignition source to the lightbar and breakout box (pink/white wire).</li> <li>• Check any splice and butt connections for proper crimp integrity.</li> <li>• Check connectors for positive engagement.</li> </ul>
NO OPERATION	
The green LED is not illuminated	<ul style="list-style-type: none"> <li>• Check Power (Pin #4) and Ground (Pin #1) on the 4-pin connector.</li> <li>• If not connected to a 400 Series Siren or bluePRINT Controller, check Ignition (pin #12) on the 24-pin connector.</li> </ul>
The red LED is not illuminated while inputs are active	<ul style="list-style-type: none"> <li>• Verify there is proper voltage on the input wire. Many inputs are positive or negative selectable (through SoundOff Central Lightbar).</li> <li>• Check lightbar program configuration using SoundOff Central Lightbar. Verify any active inputs are mapped to activate lightbar functions.</li> <li>• Verify the DIP switches on the BOB are both in the up (off) position.</li> </ul>
Green and red LEDs are illuminated properly	<ul style="list-style-type: none"> <li>• Verify the lightbar data wires on the 4-pin connector (pin #3) is correctly connected to the light bar data wire.</li> <li>• Verify the data wire circuit (from the breakout box into the lightbar) is not damaged or shorted to power or ground.</li> </ul>
NO LIGHT OPERATION IN ONE LIGHTBAR QUADRANT	
Breakout box LED's operating correctly	Remove top cover and follow the non-working modules wires to fuse location. If fuse is blown, check for shorts in cabling and LED module. Replace any damaged cables or modules and replace fuse. If fuse blows again, replace defective power distribution assembly.
No Steady Red LED on breakout box	Check 24-pin connector at breakout box (ensure it is snapped in correctly), check appropriate input to breakout box for output lights which should be on.
NO TAKEDOWNS LIGHTS	
Breakout box LED's operating correctly;	Verify configuration and make sure light modules are configured for takedown function.
No steady Red LED on breakout box;	Check 24-pin connector at breakout box (insure it is snapped in correctly), check appropriate input to breakout box for output lights which should be on.
NO OR INCORRECT WARNING LIGHTS	
	<ul style="list-style-type: none"> <li>• Verify the configuration for proper lightbar operation.</li> <li>• Verify the lightbar data wires on the 4-pin connector (pin #3) is correctly connected to the Lightbar data wire.</li> <li>• Verify light module ID/positions.</li> </ul>
INCORRECT OR NO ARROW OPERATION	
Breakout box LED's operating correctly	• Verify configuration and make sure light modules are configured for arrow function.
No steady Red LED on breakout box	• Check 24-pin connector at breakout box ( <b>ensure it is snapped into position correctly</b> ), check appropriate input to breakout box for output lights which should be on.



## WARRANTY & RETURN GOODS PROCEDURE

### CLEANING & CARE OF YOUR LIGHTBAR:

Keeping the lenses clean and scratch free will optimize the performance of the lightbar. The exterior of the lightbar including lenses should be cleaned with mild soapy water and a soft cotton cloth to remove dirt, grime and insects. Never use window cleaners or harsh chemicals on the lenses; this may cause failure of the lenses or reduce clarity resulting in the reduction of light output.

### MOUNTING INTEGRITY:

A review of bolt/hardware/mounting bracket integrity should be performed at the beginning and end of each shift.

### WARNING MESSAGES - PLEASE READ:

**WARNING** - DRILLING ANY HOLES INTO THE LIGHTBAR IS NOT RECOMMENDED! THE RISK OF DAMAGING INTERNAL COMPONENTS AND THE RESULTING FAILURE OF THE LIGHTBAR WILL VOID ANY WARRANTY OF THIS PRODUCT.

**WARNING** - CARE MUST BE TAKEN WHEN DRILLING THROUGH THE ROOF OF THE VEHICLE NOT TO DRILL INTO ANY EXISTING WIRING AND NOT TO DRILL THROUGH THE HEADLINER OR SUPPORT MEMBERS OF THE VEHICLE. CHECK BOTH SIDES OF THE MOUNTING SERVICE PRIOR TO DRILLING. DE-BURR ANY HOLES AND REMOVE ANY METAL SHARDS OR REMNANTS. INSTALL GROMMETS INTO ALL WIRE PASSAGE HOLES.

**WARNING** - ROUTE WIRES ONLY IN LOCATIONS THAT ARE NOT SUBJECTED TO POTENTIAL WEAR. MAKE SURE TO AVOID ROUTING WIRES IN THE DEPLOYMENT AREA OF YOUR AIR BAG. REFER TO YOUR VEHICLE OWNER'S MANUAL FOR AIR BAG DEPLOYMENT ZONES.

**WARNING** - ALL CUSTOMER SUPPLIED POWER WIRES CONNECTING TO THE POSITIVE (+) OR NEGATIVE (-) BATTERY TERMINAL OR LOCAL CHASSIS GROUND (-) MUST BE SIZED TO SUPPLY AT LEAST 125% OF THE MAXIMUM CURRENT AND PROPERLY FUSED AT THE POWER SOURCE WITH APPROPRIATELY RATED FUSE.

**IMPORTANT:** When passing cables through fire wall or other sheet metal, insert grommet to protect the cable!

### WARRANTY RETURN PROCESS:

Please scan QR code or visit <https://soundoffsignal.com/support-page/returns/>.



Alternatively contact your SoundOff Signal Sales Representative, Customer Services staff or our Technical Department (800.338.7337) for a RMA #, Return Merchandise Authorization Number.

The following information is required for issuance of the RMA #:

- Reason for returning the product\*
- Address where replacement product is to be shipped\*
- Telephone number where you may be reached\*
- SoundOff Signal invoice number on which product was purchased\*\*
- SoundOff Signal part number and serial number\*\*
- E-mail address where RMA # should be e-mailed\*\*
- Fax number where RMA # should be faxed\*\*

\* RMA # will not be given without this information.

\*\* If available, please provide this information.

SoundOff Signal will NOT accept returns without an RMA #. Each RMA # is good for only one (1) return and will expire (30) days after the date it was issued. Products must be shipped back to SoundOff Signal and the RMA # clearly marked on the outside of the package near the shipping label. Please use the following address on your shipping label:

SoundOff Signal  
ATTN: RMA # / Technical Services  
3900 Central Parkway  
Hudsonville, MI 49426

### WARRANTY EXCLUSIONS:

Shipping & Handling, labor and service fees are non-refundable. SoundOff Signal is not liable for any damage due to installation or personal injury as a result of using SoundOff Signal product.

### WARRANTY FORFEITURE:

Warranty will not be granted if the Warranty Return Policy & Procedure rules are not strictly followed. Physical damage resulting from customer abuse will void warranty. Warranty will also be voided if any SoundOff Signal and/or manufacturer serial tags, product stickers, seals, or the like, are removed, altered or tampered with. Returned product that is damaged by shipping via the RMA # procedure is not the responsibility of SoundOff Signal.

Document effective date on cover and below supersedes previously dated policies and statements.

There are no other warranties, expressed or implied, including, but not limited to, any implied merchantability or fitness for a particular use. SoundOff Signal reserves the right to modify this warranty statement at any time; or to discontinue, modify, or upgrade any products of its manufacture with design improvements without prior notice.