

PMP2BKUMB2-(x) - Ford F-150 2015-2020 Under Mirror Mount Bracket Kit

For 3" mpower® Stud or Quick Mount

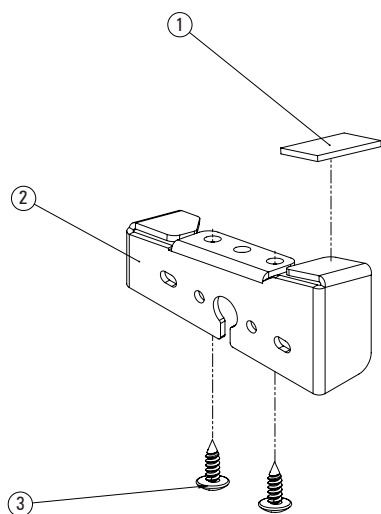

PMP2BKUMB2-P IS SHOWN*

⚠ WARNING

- HIGH CURRENT interconnects must be properly terminated. Poor crimp quality can cause heat build-up and fire. Follow crimp connector manufacturer instructions.
- DO NOT install this product or route any wires in the Air Bag Deployment Zone. Refer to vehicle Owner's Manual for deployment zones.
- Do NOT use system to disconnect headlights, brake lights or other safety equipment.
- Unit may become hot to touch during normal operation.
- Failure to properly install connectors, fuses or wiring may cause vehicle failure or fire.
- Installation must only be performed by trained technician. Installer must determine vehicle wiring configuration and proper integration of system.
- Use proper wire gauge. All power wires connecting to positive (+) or negative (-) battery terminal or local chassis ground (-) must be sized to supply at least 125% of max. current and properly fused at power source.
- Install protective grommets when routing wire through firewall or metal.



1.800.338.7337 / www.soundoffsignal.com

Installers and users must comply with all applicable federal, state and local laws regarding use and installation of warning devices.

Improper use or installation may void warranty coverage.

To review our Limited Warranty Statement & Return Policy for this or any SoundOff Signal product, visit our website at www.soundoffsignal.com/tech-services/returns/. If you have questions regarding this product, contact **Technical Services**, Monday - Friday, 8 a.m. to 5 p.m. or after hours 5 p.m. to 8 p.m. ET at 1.800.338.7337 (press #4). Questions or comments that do not require immediate attention may be emailed to techservices@soundoffsignal.com.

SUPERIOR CUSTOMER RELATIONSHIPS. SMARTLY DESIGNED LIGHTING & ELECTRONIC SOLUTIONS.

INTRODUCTION:

mpower® Fascia Light Features:

- 3" Stud Mount and Quick Mount Options available for this bracket design
- Collaboration with Dow Corning® to develop ClearDuty™ optical design
- Greater resistance to gravel pitting, scratching, or cracking
- Improved sealing to prevent water from entering light
- Higher UV and thermal stability to prevent lens from yellowing over time

PART#	YEAR, MAKE, AND MODEL	*COMPATIBLE WITH...
PMP2BKUMB2-(D)	2015-2020 Ford F-150	3" mpower®, Stud or Quick Mount, Driver Side
PMP2BKUMB2-(P)	2015-2020 Ford F-150	3" mpower®, Stud or Quick Mount, Passenger Side

CONTENTS

ITEM#	QTY	COMPONENT
1	2	1" X 3" VHB TAPE
2	1	UNDERMIRROR 90 DEGREE BRACKET
3	2	#8 X .50 SM TRUSSHEAD PHILLIPS SCREW
	1	SURFACE PREP WIPE
	1	PRODUCT WARNING CARD
	1	INSTRUCTION SHEET

*Installation instructions are for the passenger side bracket (PMP2BKUMB2-P). Installation for the driver side is the same.

NOTICE:

PMP2BKUMB2-(x) - Ford F-150 2015-2020 Under Mirror Mount Bracket Kit

For 3" mpower® Stud or Quick Mount

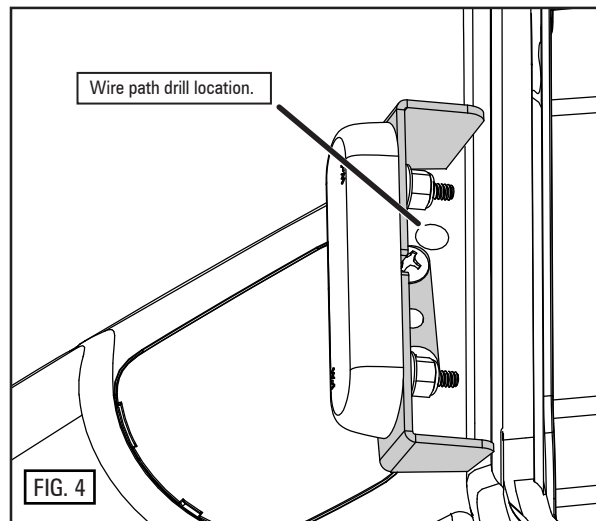
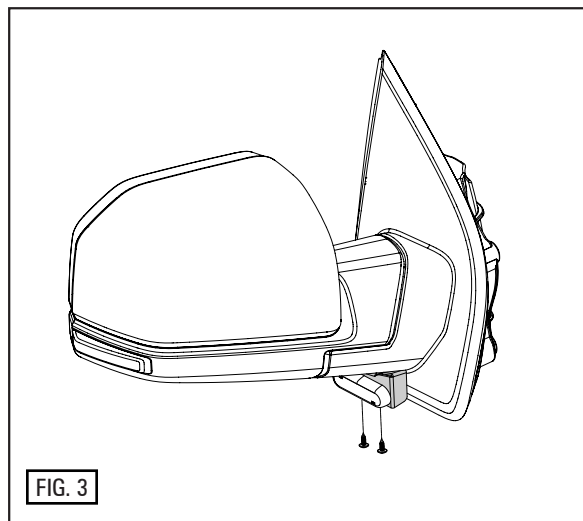
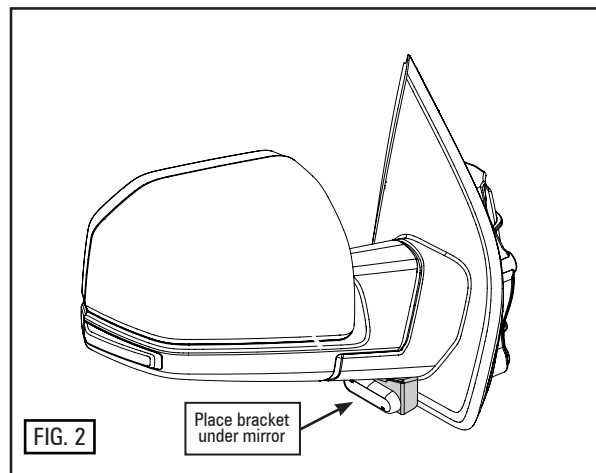
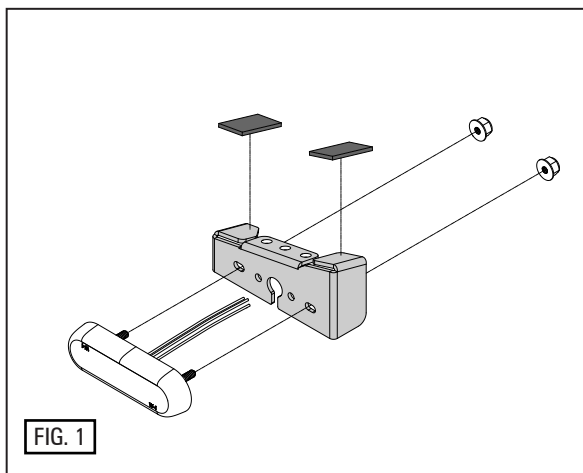

INSTALLATION

1. Mount light onto bracket with hardware provided with the light.
2. Clean the top of the bracket and the underside of the vehicle mirror with alcohol pad to ensure a clean mounting surface.
3. Cut VHB adhesive to size and apply to the top of the mounting bracket, as seen in FIG. 1.
4. Mount the bracket to the underside of mirror. Make sure the bracket is not resting on the painted surface. Apply pressure for 30 seconds to ensure bracket is attached to mirror, as seen in FIG. 2.
5. Remove the mirror housing from vehicle according to the manufacturer specs.
6. Using the screw holes in bracket as a guide, drill holes for the stainless screws with a 7/64" drill bit (be careful not to damage wiring in mirror housing.) Install provided stainless screws through bracket into mirror housing. Tighten until screw is snug, as seen in FIG. 3.
7. Run wires into mirror. A hole may need to be drilled to create a path for the wires, as seen in FIG. 4.
8. Re-install the mirror and tighten to manufacturer specifications.

NOTICE:

Installers and users must comply with all applicable federal, state and local laws regarding use and installation of warning devices.

Improper use or installation may void warranty coverage.

To review our Limited Warranty Statement & Return Policy for this or any SoundOff Signal product, visit our website at www.soundoffsignal.com/tech-services/returns/. If you have questions regarding this product, contact **Technical Services**, Monday - Friday, 8 a.m. to 5 p.m. or after hours 5 p.m. to 8 p.m. ET at 1.800.338.7337 (press #4). Questions or comments that do not require immediate attention may be emailed to techservices@soundoffsignal.com.

**SoundOff
Signal** 
Smart Design.

1.800.338.7337 / www.soundoffsignal.com

SUPERIOR CUSTOMER RELATIONSHIPS. SMARTLY DESIGNED LIGHTING & ELECTRONIC SOLUTIONS.