

nFUSE® P BACKUP LIGHT

EPSSCOJ(xx)-(x) - 7X3 P Backup - Screw Mount & Stud Mount
 EPSSBOJX(x)-(x) - 6X4 P Backup - Screw Mount & Stud Mount

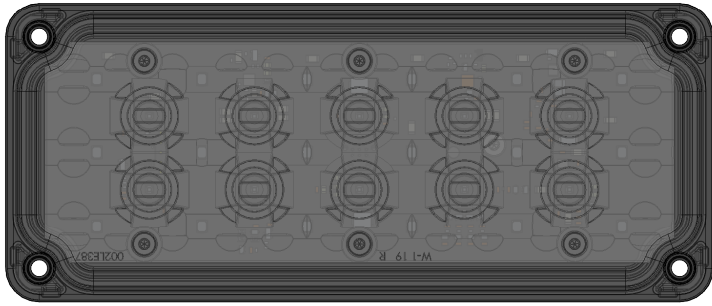

7x3 Backup Light Shown

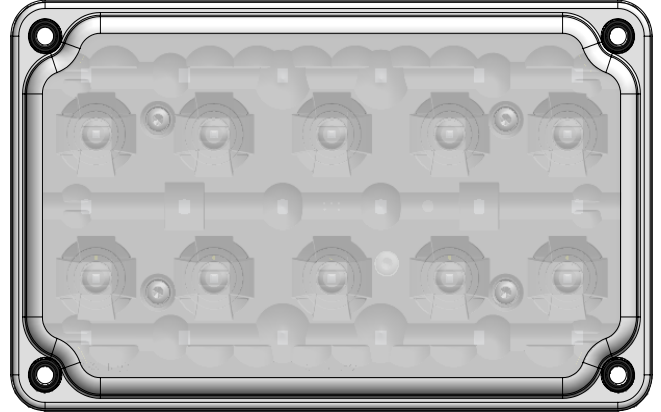

6x4 Backup Light Shown

Protected by U.S. Patent 10,703,260 and Patents Pending
<https://soundoffsignal.com/legal/patent-notification/>

WARNING

- HIGH CURRENT interconnects must be properly terminated. Poor crimp quality can cause heat build-up and fire. Follow the crimp connector manufacturer instructions.
- DO NOT install this product or route any wires in the Air Bag Deployment Zone. Refer to vehicle Owner's Manual for deployment zones.
- Do NOT use system to disconnect headlights, brake lights or other safety equipment.
- Unit may become hot to touch during normal operation.
- Failure to properly install connectors, fuses or wiring may cause vehicle failure or fire.
- Installation must only be performed by trained technician. Installer must determine vehicle wiring configuration and proper integration of system.
- Use proper wire gauge. All power wires connecting to positive (+) or negative (-) battery terminal or local chassis ground (-) must be sized to supply at least 125% of max. current and properly fused at power source.
- Install protective grommets when routing wire through firewall or metal.

NOTICE:

Installers and users must comply with all applicable federal, state and local laws regarding use and installation of warning devices. *Improper use or installation may void warranty coverage. To review our Limited Warranty Statement & Return Policy for this or any SoundOff Signal product, visit our website at www.soundoffsignal.com/tech-services/returns/. If you have questions regarding this product, contact **Technical Services**, Monday - Friday, 8 a.m. to 5 p.m. ET at **1.800.338.7337** (press #4). Questions or comments that do not require immediate attention may be emailed to techservices@soundoffsignal.com.*

DIMENSIONS 2

WARNING LIGHT OPTIONS 2

TECHNICAL SPECIFICATIONS 3

WIRING INFORMATION 4-5

STUD MOUNT INSTALLATION 6

SCREW MOUNT INSTALLATION 7

RETENTION CLIP INSTRUCTIONS 8

NOTES 9

WARRANTY 10

 **WARNING**

ROUTE WIRES ONLY IN LOCATIONS THAT ARE NOT SUBJECTED TO POTENTIAL WEAR. MAKE SURE TO AVOID ROUTING WIRES IN THE DEPLOYMENT AREA OF YOUR AIR BAG. REFER TO YOUR VEHICLE'S OWNER'S MANUAL FOR AIRBAG DEPLOYMENT ZONES.



1.800.338.7337 / www.soundoffsignal.com

ENHANCING SAFETY THROUGH INNOVATION

7X3 / 6X4 nFUSE P BACKUP
 00KPJL 0623 REV C

DIMENSIONS & BEZEL INFORMATION: //////////////////////////////////////////////////////////////////

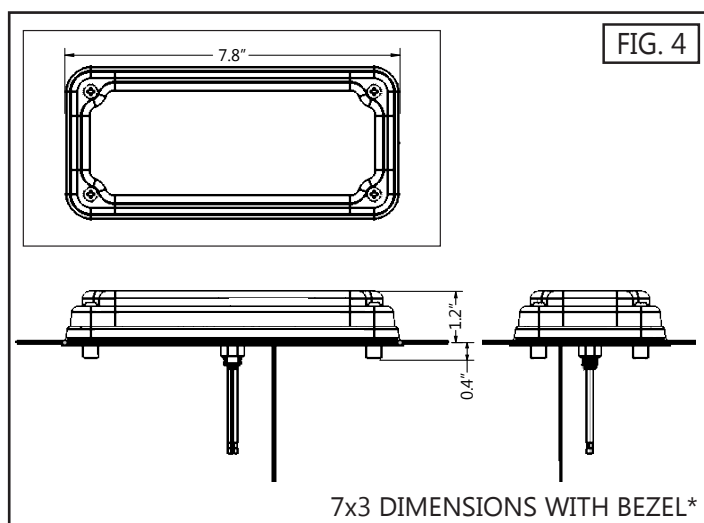
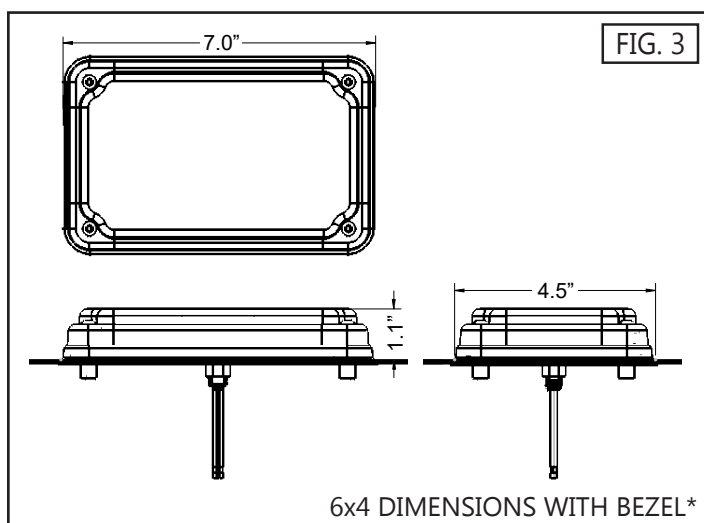
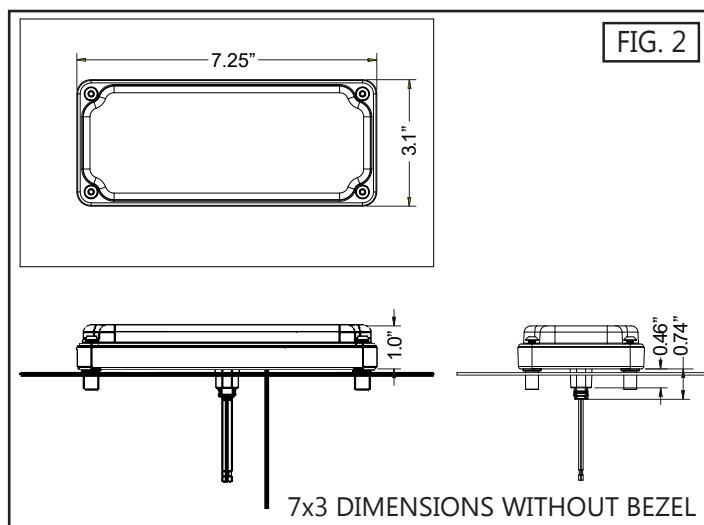
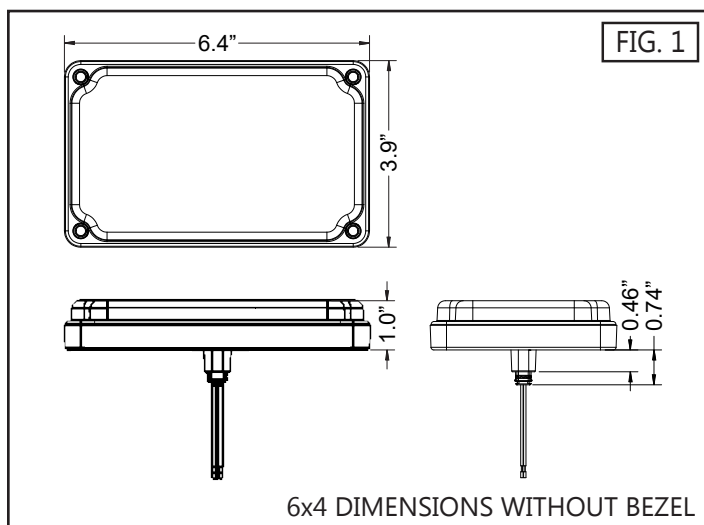

*Single Bezels are only compatible with Stud & Screw mount versions.

BACKUP LIGHT WITH WARNING OPTIONS: //////////////////////////////////////////////////////////////////

7x3 & 6x4 LED OPTIONS

- Single Color

7x3 & 6x4 LED COLOR OPTIONS

- Red
- Amber
- Blue
- White
- Green

7x3 & 6x4 LENS COLOR OPTIONS

- Red
- Amber
- Blue
- Clear
- Green

7x3 & 6x4 CERTIFICATIONS

- SAEJ595
- California Title 13
- FMVSS108 (Backup light Only)
- NFPA 1901-2009
- KKK-A-1822 (July 2021)

7x3 & 6x4 MOUNTING OPTIONS

- Stud Mount
- Screw Mount

7x3 & 6x4 AVAILABLE FLASH PATTERNS

- Double*
- Double 2*
- Inter-cycle
- Power Pulse*
- Q-switch
- Quad*
- Quad 2*
- Quad Pulse-pop*
- Quint*
- Random 1
- Random 2
- Road Runner*
- Steady-Burn Driver Title 13 Quad
- Steady-Burn/Road Runner
- Warp

*Certified Flash Patterns

PART NUMBERS (UNCONFIGURED)

- 7x3 - EPSSC0J XX-X**
- 6x4 - EPSSB0JX X-X**

**See SoundOff Signal configurator or sales representative for specific color, lens, and mounting options.

TECHNICAL SPECIFICATIONS:

7X3 & 6X4 P SERIES BACKUP LIGHT W/ WARNING TECHNICAL SPECIFICATIONS				
	Input Voltage:		9-32Vdc	
	BACKUP LIGHT WITH WARNING CURRENT CONSUMPTION (Amps)			
	12.8Vdc		25.6Vdc	
	Peak	Average	Peak	Average
Red	1.45	0.73	0.73	0.36
Amber, Blue, Green, or White	1.66	0.83	0.83	0.42
AFTER POWER IS ON, touching the WHITE wire to the ground will allow you to change various settings on the module. (Refer to page 4)				

7X3 & 6X4 P SERIES BACKUP LIGHT TECHNICAL SPECIFICATIONS			
	Input Voltage:		9-32Vdc
	BACKUP LIGHT CURRENT CONSUMPTION (Amps)		
	12.8Vdc		25.6Vdc
	Peak	Peak	
Red	0.55	0.28	
Amber, Blue, Green, or White	0.26	0.13	
AFTER POWER IS ON, touching the WHITE wire to the ground will allow you to change various settings on the module. (Refer to page 4)			

STUD MOUNT INSTALLATION: //////////////////////////////////////////////////////////////////////////////////////////////////////////////////////////////////////////////////////////////////////

1. Drill (2) 1/4" holes to mount light and 3/4" wire hole (see **Fig. 7**).
The drill template shown is compatible with both the the 6x4 and 7x3 stud mount light.
2. Thread studs into the back of light.
3. Place bezel over front of light.
4. Align the gasket to the mounting surface. Horizontal and vertical orientations are indicated on gasket for proper seal.
5. Press light/bezel assembly against gasket, against mount surface.
6. Secure the light to mounting surface using (2) supplied nuts, on the back side of vehicle mount surface.

NOTE: Tighten until gasket is compressed. DO NOT over tighten and strip casting threads. **DO NOT USE POWER TOOLS TO TIGHTEN.**

8. Plug the wire harness into the back of the light. Reference **page 8** for retention clip installation.

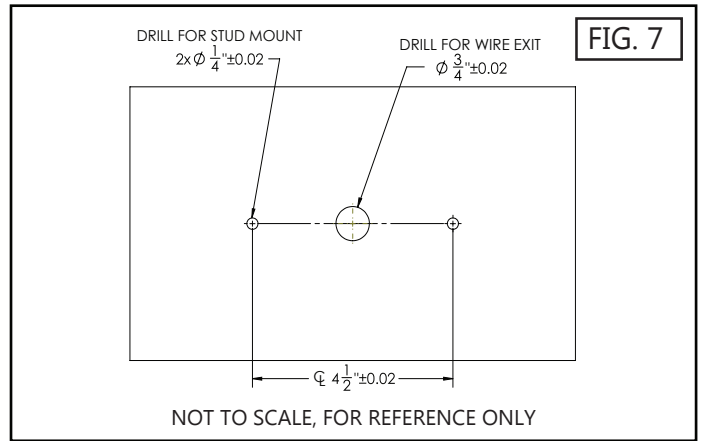
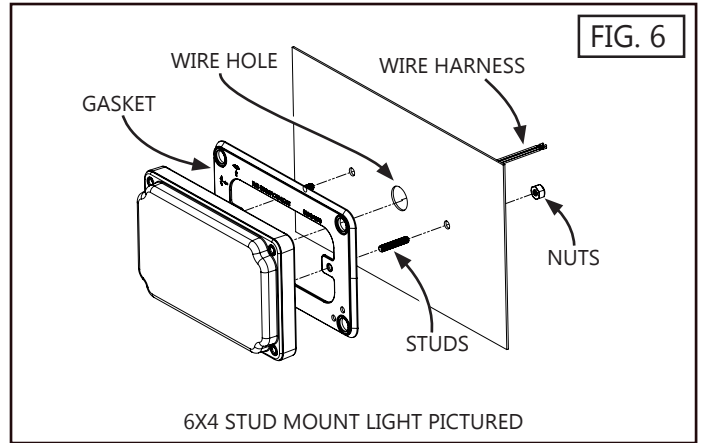

SCREW MOUNT INSTALLATION:

- 1. Drill (4) 5/16" holes to mount light. Drill 3/4" wire hole. See Fig. 9 (7x3) OR Fig. 10 (6x4).
- 2. If a bezel is being used, place bezel over light.
- 3. Place the gasket on the back of the light and bezel (if used).

NOTE: Horizontal and vertical orientations indicated on gasket for proper seal.

- 4. Insert the (4) supplied screws into each screw hole.
- 5. Place (4) flat washers over the screws on the back of the light.
- 6. Screw onto each fastener the (4) well nuts onto the back of the light. Tighten until snug.
- 7. Pull the wire harness through the opening and plug into the back of the light. Reference page 8 for retention clip installation.
- 8. With the light assembly in hand, insert the well nuts into the 4 drilled holes. Fully seat to mounting surface.
- 9. Secure the light to mounting surface. While applying pressure on each fastener, tighten the (4) screws 7 full turns.

NOTE: Tighten until gasket is compressed. DO NOT over tighten.

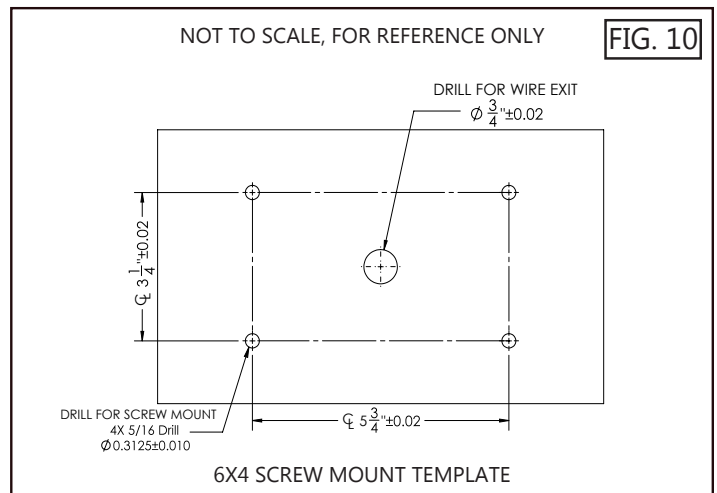
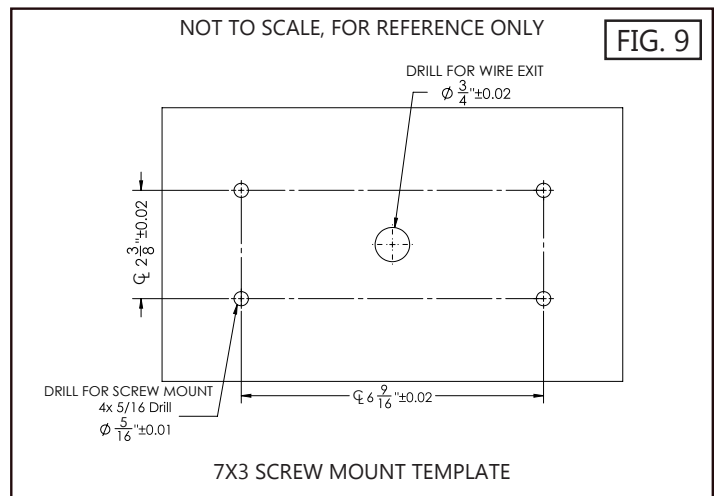
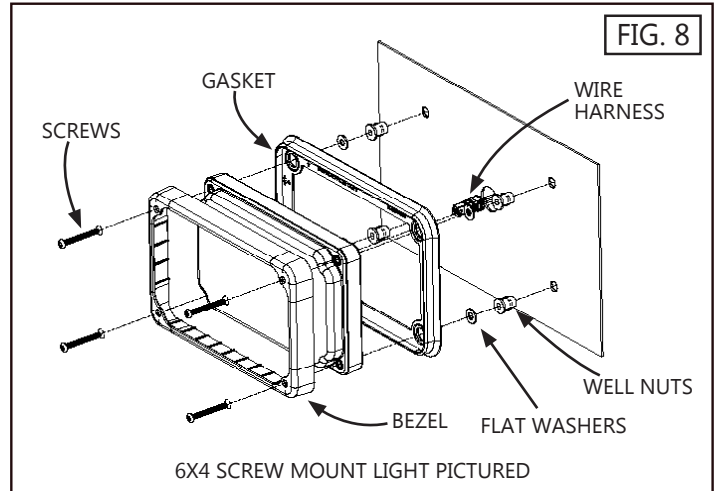

RETENTION CLIP INSTRUCTIONS:

NOTE: In the event the harness needs to be disengaged from the light, these instructions can be used to reattach and apply the retention clip.

1. Plug harness into light housing, aligning tab to window, as shown in **Fig 13**.
2. Install the retainer clip over harness/light interface, inserting retainer into window, as shown in **Fig. 14**.
3. Press retainer clip's locking arm to snap closed.

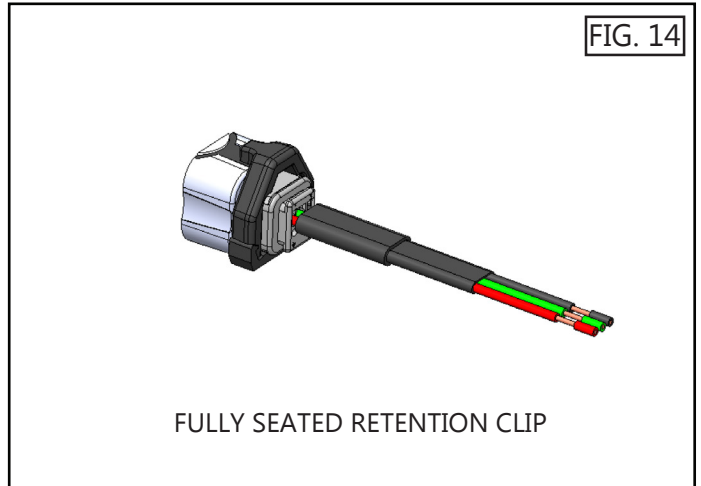
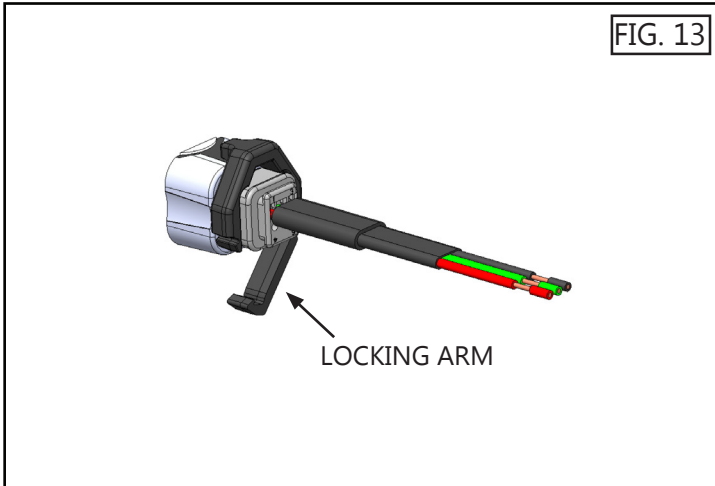
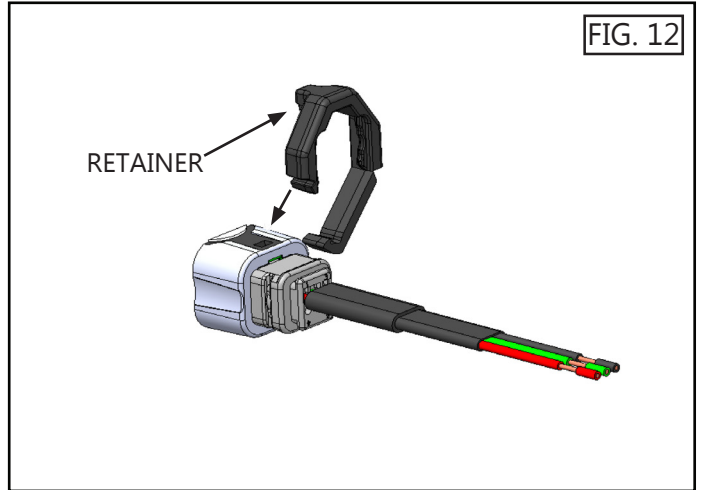
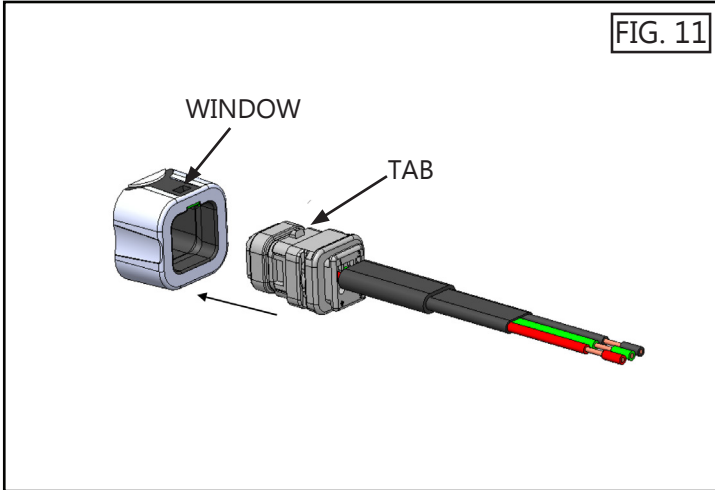

WARRANTY & RETURN GOODS PROCEDURE

CLEANING & CARE OF YOUR LIGHTBAR:

Keeping the lenses clean and scratch free will optimize the performance of the light. The exterior of the light including lenses should be cleaned with mild soapy water and a soft cotton cloth to remove dirt, grime and insects. Never use window cleaners or harsh chemicals on the lenses; this may cause failure of the lenses or reduce clarity resulting in the reduction of light output.

MOUNTING INTEGRITY:

A review of bolt/hardware/mounting bracket integrity should be performed at the beginning and end of each shift.

WARNING MESSAGES - PLEASE READ:

WARNING - CARE MUST BE TAKEN WHEN DRILLING THROUGH THE VEHICLE NOT TO DRILL INTO ANY EXISTING WIRING AND NOT TO DRILL THROUGH THE HEADLINER OR SUPPORT MEMBERS OF THE VEHICLE. CHECK BOTH SIDES OF THE MOUNTING SERVICE PRIOR TO DRILLING. DE-BURR ANY HOLES AND REMOVE ANY METAL SHARDS OR REMNANTS.

WARNING - ROUTE WIRES ONLY IN LOCATIONS THAT ARE NOT SUBJECTED TO POTENTIAL WEAR. MAKE SURE TO AVOID ROUTING WIRES IN THE DEPLOYMENT AREA OF YOUR AIR BAG. REFER TO YOUR VEHICLE OWNER'S MANUAL FOR AIR BAG DEPLOYMENT ZONES.

WARNING - ALL CUSTOMER SUPPLIED POWER WIRES CONNECTING TO THE POSITIVE (+) OR NEGATIVE (-) BATTERY TERMINAL OR LOCAL CHASSIS GROUND (-) MUST BE SIZED TO SUPPLY AT LEAST 125% OF THE MAXIMUM CURRENT AND PROPERLY FUSED AT THE POWER SOURCE WITH APPROPRIATELY RATED FUSE.

IMPORTANT: When passing cables through fire wall or other sheet metal, insert grommet to protect the cable!

WARRANTY RETURN PROCESS:

Please scan QR code or visit <https://soundoffsignal.com/support-page/returns/>



Alternatively contact your SoundOff Signal Sales Representative, Customer Services staff or our Technical Department (800.338.7337) for a RMA #, Return Merchandise Authorization Number.

The following information is required for issuance of the RMA #:

- Reason for returning the product*
- Address where replacement product is to be shipped*
- Telephone number where you may be reached*
- SoundOff Signal invoice number on which product was purchased**
- SoundOff Signal part number and serial number**
- E-mail address where RMA # should be e-mailed**
- Fax number where RMA # should be faxed**

* RMA # will not be given without this information.

** If available, please provide this information.

SoundOff Signal will NOT accept returns without an RMA #. Each RMA # is good for only one (1) return and will expire (30) days after the date it was issued. Products must be shipped back to SoundOff Signal and the RMA # clearly marked on the outside of the package near the shipping label. Please use the following address on your shipping label:

SoundOff Signal
ATTN: RMA # / Technical Services
3900 Central Parkway
Hudsonville, MI 49426

WARRANTY EXCLUSIONS:

Shipping & Handling, labor and service fees are non-refundable. SoundOff Signal is not liable for any damage due to installation or personal injury as a result of using SoundOff Signal product.

WARRANTY FORFEITURE:

Warranty will not be granted if the Warranty Return Policy & Procedure rules are not strictly followed. Physical damage resulting from customer abuse will void warranty. Warranty will also be voided if any SoundOff Signal and/or manufacturer serial tags, product stickers, seals, or the like, are removed, altered or tampered with. Returned product that is damaged by shipping via the RMA # procedure is not the responsibility of SoundOff Signal.

Document effective date on cover and below supersedes previously dated policies and statements.

There are no other warranties, expressed or implied, including, but not limited to, any implied merchantability or fitness for a particular use. SoundOff Signal reserves the right to modify this warranty statement at any time; or to discontinue, modify, or upgrade any products of its manufacture with design improvements without prior notice.