

BACKUP LIGHT

EMPSC07M(x)-(x) - 7X3 Quick Mount, Screw Mount, & Stud Mount
 EMPSB0C9(x)-(x) - 6X4 Quick Mount, Screw Mount, & Stud Mount

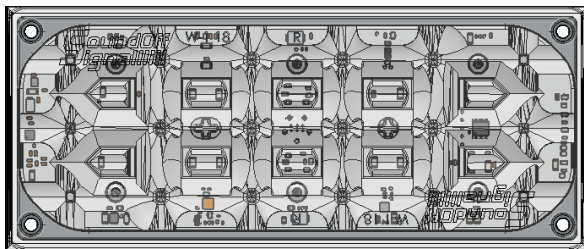

7x3 Backup Light Shown

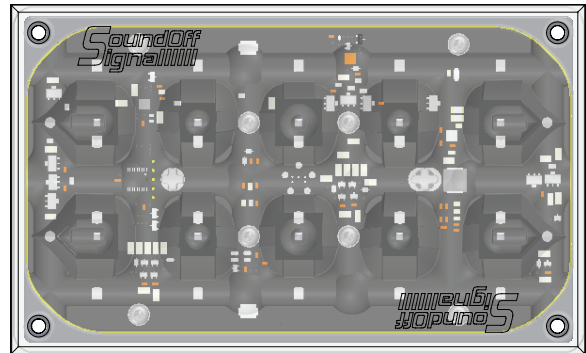

6x4 Backup Light Shown

Protected by U.S. Patent 10,703,260 and Patents Pending
<https://soundoffsignal.com/legal/patent-notification/>

WARNING

- HIGH CURRENT interconnects must be properly terminated. Poor crimp quality can cause heat build-up and fire. Follow the crimp connector manufacturer instructions.
- DO NOT install this product or route any wires in the Air Bag Deployment Zone. Refer to vehicle Owner's Manual for deployment zones.
- Do NOT use system to disconnect headlights, brake lights or other safety equipment.
- Unit may become hot to touch during normal operation.
- Failure to properly install connectors, fuses or wiring may cause vehicle failure or fire.
- Installation must only be performed by trained technician. Installer must determine vehicle wiring configuration and proper integration of system.
- Use proper wire gauge. All power wires connecting to positive (+) or negative (-) battery terminal or local chassis ground (-) must be sized to supply at least 125% of max. current and properly fused at power source.
- Install protective grommets when routing wire through firewall or metal.
- Petroleum/silicone based lubricants will cause the silicone lens to discolor.

DIMENSIONS 2

BACKUP LIGHT OPTIONS 2

TECHNICAL SPECIFICATIONS 3

WIRING INFORMATION 4-5

QUICK MOUNT INSTALLATION 6

STUD MOUNT INSTALLATION 6

SCREW MOUNT INSTALLATION 7

RETENTION CLIP INSTRUCTIONS 8

WARNING

ROUTE WIRES ONLY IN LOCATIONS THAT ARE NOT SUBJECTED TO POTENTIAL WEAR. MAKE SURE TO AVOID ROUTING WIRES IN THE DEPLOYMENT AREA OF YOUR AIR BAG. REFER TO YOUR VEHICLE'S OWNER'S MANUAL FOR AIRBAG DEPLOYMENT ZONES.



1.800.338.7337 / www.soundoffsignal.com

NOTICE:

Installers and users must comply with all applicable federal, state and local laws regarding use and installation of warning devices. *Improper use or installation may void warranty coverage. To review our Limited Warranty Statement & Return Policy for this or any SoundOff Signal product, visit our website at www.soundoffsignal.com/tech-services/returns/. If you have questions regarding this product, contact **Technical Services**, Monday - Friday, 8 a.m. to 5 p.m. ET at **1.800.338.7337** (press #4). Questions or comments that do not require immediate attention may be emailed to techservices@soundoffsignal.com.*

ENHANCING SAFETY THROUGH INNOVATION

DIMENSIONS & BEZEL INFORMATION: //

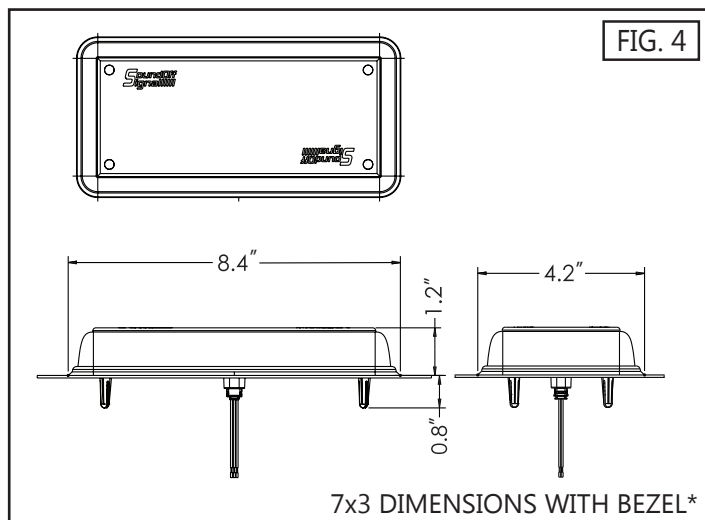
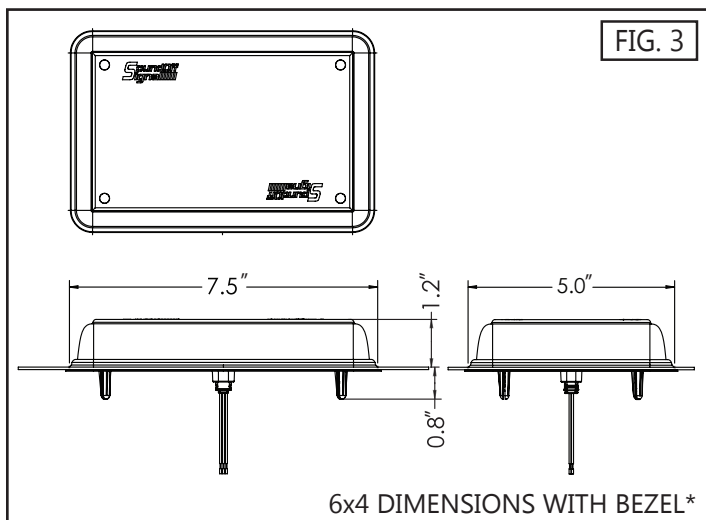
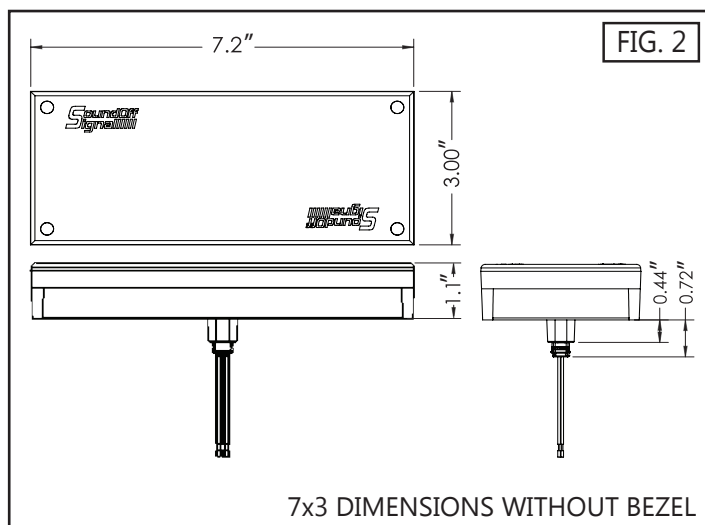
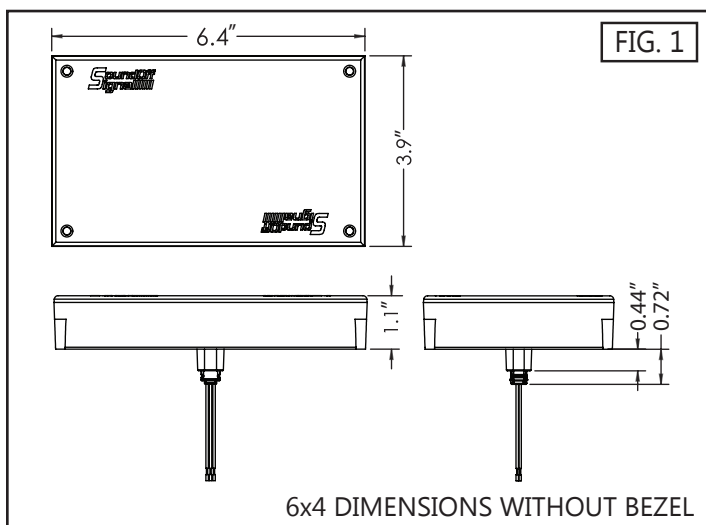

*Single Bezels are only compatible with Stud & Screw mount versions.

BACKUP LIGHT W/ WARNING OPTIONS: //

7x3 & 6x4 LED OPTIONS

- Single Color

7x3 & 6x4 LED COLOR OPTIONS

- Red
- Amber
- Blue
- White
- Green

7x3 & 6x4 CERTIFICATIONS

- SAEJ595
- California Title 13
- NFPA 1901-2009
- KKK-A-1822 (July 2021)
- FMVSS108 (*Backup light Only*)

7x3 & 6x4 MOUNTING OPTIONS

- Quick Mount (*Not compatible with Bezel*)
- Stud Mount
- Screw Mount

7x3 & 6x4 AVAILABLE FLASH PATTERNS

- Double*
- Double 2*
- Inter-cycle
- Power Pulse*
- Q-switch
- Quad*
- Quad 2*
- Quad Pulse-pop*
- Quint*
- Random 1
- Random 2
- Road Runner*
- Steady-Burn Driver Title 13 Quad
- Steady-Burn/Road Runner
- Warp

*Certified Flash Patterns

PART NUMBERS (UNCONFIGURED)

- 7x3 - EMPSC0 XXX-X**
- 6x4 - EMPSB0 XXX-X**

**See SoundOff Signal configurator or sales representative for specific color, lens, and mounting options.

TECHNICAL SPECIFICATIONS: //

MPOWER® 7X3 & 6X4 BACKUP LIGHT W/ WARNING TECHNICAL SPECIFICATIONS				
	Input Voltage:		9-32Vdc	
	BACKUP LIGHT WITH WARNING CURRENT CONSUMPTION (Amps)			
	12.8Vdc		25.6Vdc	
	Peak	Average	Peak	Average
Red	1.45	0.73	0.73	0.36
Amber, Blue, Green, or White	1.66	0.83	0.83	0.42
AFTER POWER IS ON, touching the WHITE wire to the ground will allow you to change various settings on the module. (Refer to page 4)				

MPOWER® 7X3 & 6X4 BACKUP LIGHT TECHNICAL SPECIFICATIONS			
	Input Voltage:		9-32Vdc
	BACKUP LIGHT CURRENT CONSUMPTION (Amps)		
	12.8Vdc		25.6Vdc
	Peak		Peak
HIGH (SINGLE)	0.86	0.43	
LOW (DUAL)	0.43	0.22	
AFTER POWER IS ON, touching the WHITE wire to the ground will allow you to change various settings on the module. (Refer to page 4)			

WIRING AND TABLE INFORMATION: //

OVER-VOLTAGE PROTECTION

When an over-voltage condition is detected, the module will flash an overvoltage warning pattern of 50mS ON/950mS OFF to alert of the overvoltage condition and protect the electronics from damage due to heat/voltage.

THERMAL COMPENSATION PROTECTION

The LED module is designed to provide maximum power output while providing protection to the electronic components by reducing the output power at extreme temperatures.

CERTIFICATION	APPLICABLE COLORS
SAEJ595	Red, Amber, Blue, White, Green
CALIFORNIA TITLE 13	Red, Amber, Blue
NFPA 1901-2009	Red, Amber, Blue, White
KKK-A-1822F (JULY 2021)	Red, Amber, Blue, White, Green
FMVSS108 (<i>Backup Only</i>)	White

FUNCTION TABLE				
WIRE			LIGHT	
RED	ORANGE	WHITE	BACKUP LIGHT WITH WARNING	BACKUP LIGHT ONLY
+9-32V	-	-	FLASH WARNING COLOR	FMVSS SINGLE LAMP SYSTEM BACKUP
-	+9-32V	-	STEADY BACKUP HIGH POWER	FMVSS DUAL LAMP SYSTEM BACKUP
+9-32V	+9-32V	-	STEADY BACKUP HIGH POWER	FMVSS SINGLE LAMP SYSTEM BACKUP
-	-	+9-32V	NO OP	NO OP
+9-32V	-	+9-32V	FLASH WARNING COLOR LOW POWER	FMVSS SINGLE LAMP SYSTEM BACKUP
-	+9-32V	+9-32V	STEADY BACKUP LOW POWER	FMVSS DUAL LAMP SYSTEM BACKUP
+9-32V	+9-32V	+9-32V	STEADY BACKUP LOW POWER	FMVSS SINGLE LAMP SYSTEM BACKUP

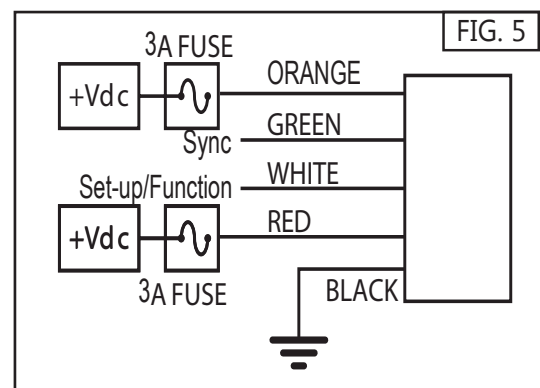

Lights are chassis-grounded. If you need to ground-switch the light, you must isolate the lights metal backing, heatsink, studs and/or screws from the body of the vehicle or use a relay.

FEDERAL MOTOR VEHICLE SAFETY STANDARDS (FMVSS) COMPLIANCE

To be compliant with FMVSS when using the backup function, the following settings are required:

- Single lamp system – Set the light to Steady Backup High Power
- Dual lamp system – Set each light to Steady Backup Low Power

REMOTE NODE: FOR USE WITH bluePRINT® SYSTEM ONLY

Connecting the Green wire to ground before applying power to the Red or Orange wires will place the LED module into remote mode and the light output color will be directly controlled by the input wires as shown below. For Cruise mode or Low Power control of the LED module, the signal to the control wires must be 100 +/- 2Hz using the duty cycle inputs listed below to produce the light output.

MPOWER® 6x4 & 7x3 BACKUP LIGHT WITH WARNING REMOTE NODE FUNCTIONALITY		
RED	ORANGE	LIGHT
CRUISE	-	CRUISE WARNING COLOR
-	CRUISE	CRUISE BACKUP COLOR
CRUISE	CRUISE	CRUISE BACKUP COLOR
FLASH	-	FLASH WARNING COLOR
-	FLASH	FLASH BACKUP COLOR
FLASH	FLASH	FLASH BACKUP COLOR
STEADY ON	-	STEADY WARNING COLOR
-	STEADY ON	STEADY BACKUP COLOR
STEADY ON	STEADY ON	STEADY BACKUP COLOR
CRUISE	FLASH	FLASH BACKUP COLOR

MPOWER® 6x4 & 7x3 BACKUP LIGHT ONLY REMOTE NODE FUNCTIONALITY		
RED	ORANGE	LIGHT
CRUISE	-	CRUISE BACKUP COLOR
FLASH	-	FLASH BACKUP COLOR
STEADY	-	STEADY BACKUP COLOR

CRUISE MODE DUTY CYCLE (@ 100Hz)	
Input	Light Output
40%	OFF
50%	5%
60%	10%

LOW POWER FLASH D.C. (@ 100Hz)	
Input	Light Output
70%	30%
80%	40%
90%	50%

QUICK MOUNT INSTALLATION:

1. Drill a 3/4" wire hole (see **Fig. 7**).
2. Insert (4) Silicone Plugs into Light to Seal Screw Holes. (Use a 50% Isopropyl alcohol, 50% deionized water mix for lubrication if necessary).



3. Prep the back of the light and vehicle mount surfaces with 50% deionized water, 50% isopropyl alcohol wipe, and allow to dry.
4. Adhere VHB quick mount to the back of the light and press down firmly for 15 seconds on full surface.
5. Pull the wire harness through the vehicle wire hole and plug into the back of the light. Reference **page 8** for retention clip installation.
6. Lightly place the light against vehicle mount surface and check that the alignment is satisfactory. Once alignment is correct press firmly against light for 15 seconds to set VHB quick mount.

NOTE: Bezels will not work with the Quick Mount option.

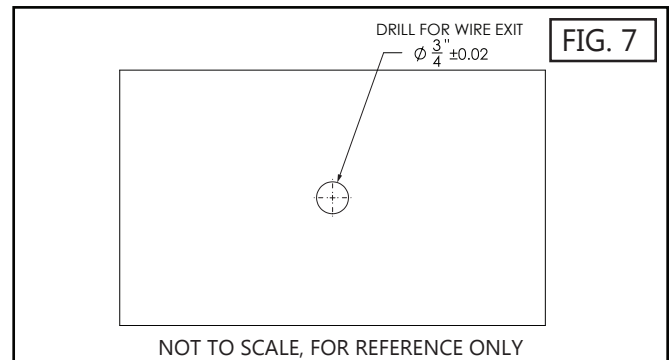
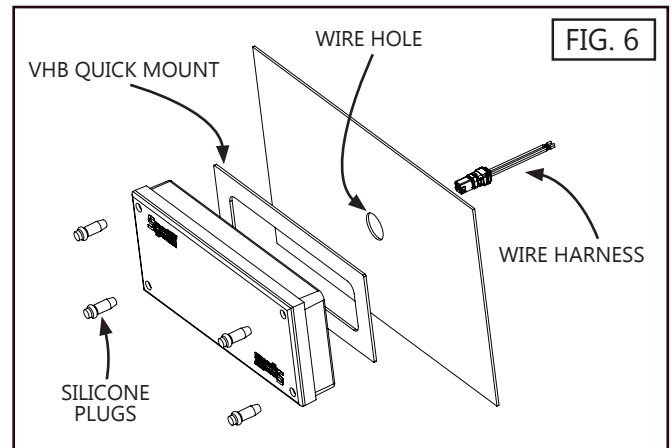

STUD MOUNT INSTALLATION:

1. Drill (2) 1/4" holes to mount light. Drill 3/4" wire hole (see **Fig. 9**). The drill template shown is compatible with both the the 6x4 and 7x3 stud mount light.
2. Insert (4) Silicone Plugs into Light to Seal Screw Holes. (Use a 50% Isopropyl alcohol, 50% deionized water mix for lubrication if necessary).



3. Thread studs into the back of light.
4. Align the gasket to the mounting surface. Horizontal and vertical orientations are indicated on gasket for proper seal.
5. Place the bezel over gasket.
6. Place the light into bezel, press firmly to make sure bezel and gasket are tight against mounting surface.
7. Secure the light to mounting surface using (2) supplied nuts.

NOTE: Tighten until gasket is compressed. DO NOT over tighten and strip casting threads. **DO NOT USE POWER TOOLS TO TIGHTEN.**

8. Plug the wire harness into the back of the light. Reference **page 8** for retention clip installation.

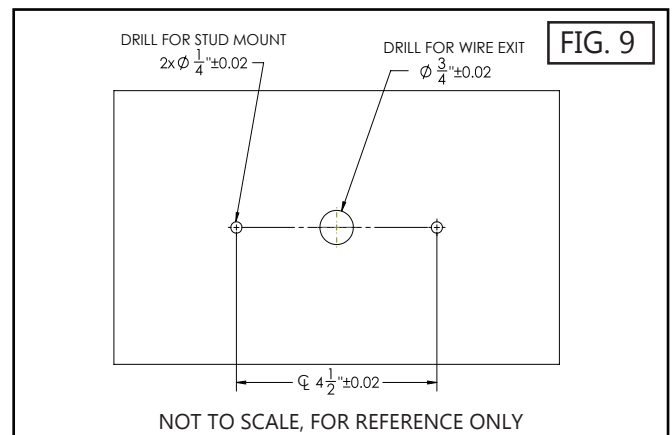
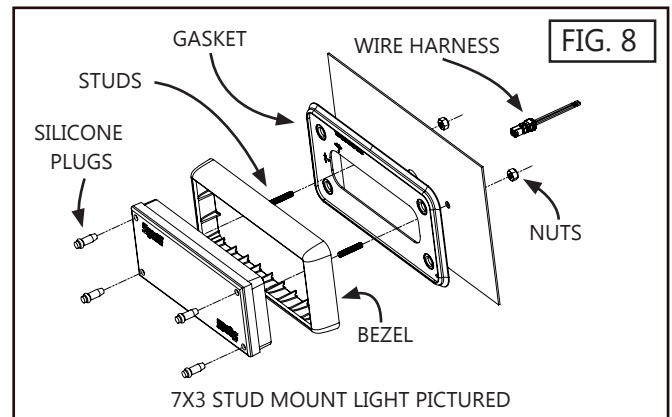

SCREW MOUNT INSTALLATION:

1. Drill (4) 5/16" holes to mount light. Drill 3/4" wire hole. See Fig. 11(7x3) or Fig. 12(6x4).
2. If a bezel is being used, place the light into the bezel.
3. Place the gasket on the back of the light and bezel (if used)

NOTE: Horizontal and vertical orientations indicated on gasket for proper seal.

4. Insert the (4) supplied screws into each screw hole in the light.
5. Place (4) flat washers over the screws on the back of the light.
6. Screw onto each fastener the (4) well nuts onto the back of the light. Tighten until snug.
7. Pull the wire harness through the opening and plug into the back of the light.
8. With the light assembly in hand, insert the well nuts into the (4) drilled holes. Fully seat to mounting surface.
9. Secure the light to mounting surface. While applying pressure on each fastener, tighten the (4) screws 7 full turns.

NOTE: Tighten until gasket is compressed. DO NOT over tighten.

10. Insert (4) Silicone Plugs into the light to seal screw holes. (Use a 50% Isopropyl alcohol, 50% deionized water mix for lubrication if necessary).

NOTE: Bezel required for any mounting not protected by intentionally recessed designed mounting locations.

DO NOT USE POWER DRIVER.

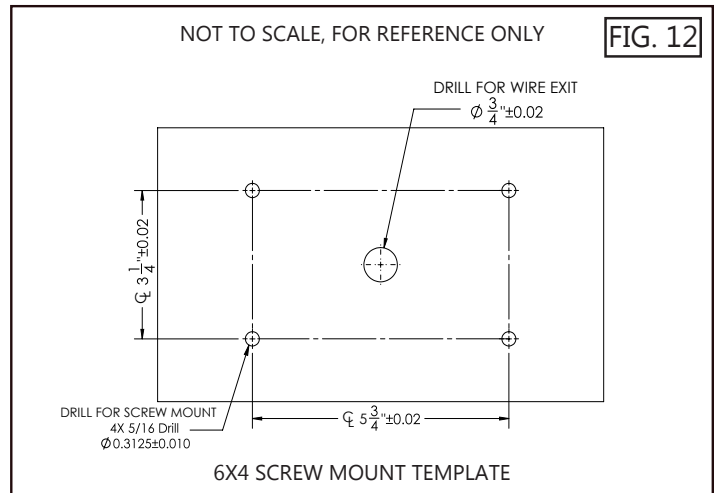
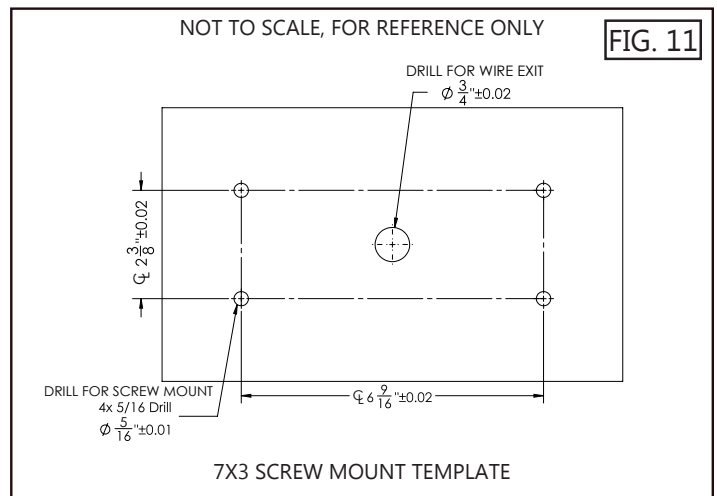
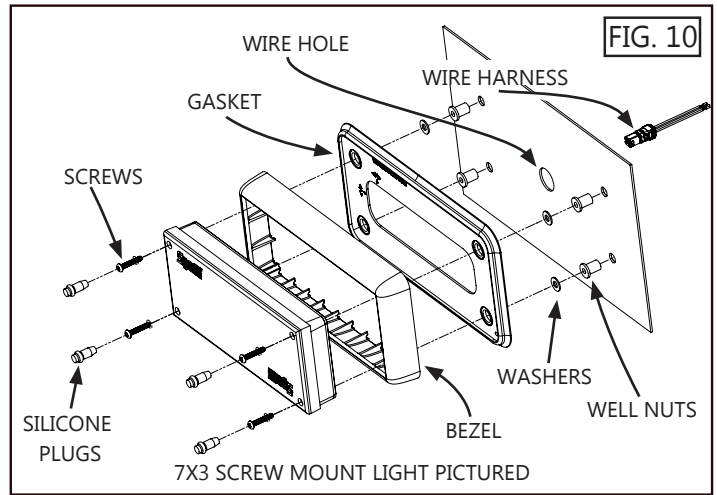

⚠ WARNING
 PETROLEUM/SILICONE BASED
 LUBRICANTS WILL CAUSE THE
 SILICONE LENS TO DISCOLOR.

RETENTION CLIP INSTRUCTIONS: //

NOTE: In the event the harness needs to be disengaged from the light, these instructions can be used to reattach and apply the retention clip.

1. Plug harness into light housing, aligning tab to window, as shown in **Fig 13**.
2. Install the retainer clip over harness/light interface, inserting retainer into window, as shown in **Fig. 14**.
3. Press retainer clip's locking arm to snap closed.

