

WARNING LIGHT

EMPSC07M(x)-(x) - 7X3 Quick Mount, Screw Mount, & Stud Mount
 EMPSB0C9(x)-(x) - 6X4 Quick Mount, Screw Mount, & Stud Mount

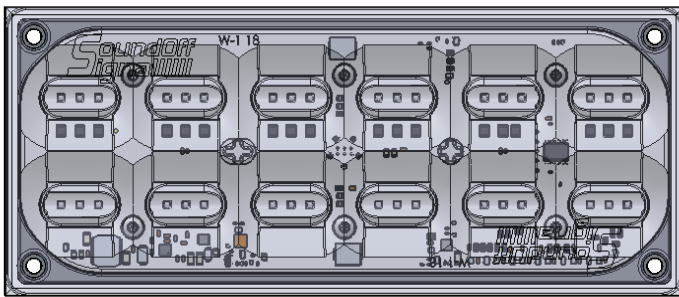

7x3 Tri-color Shown

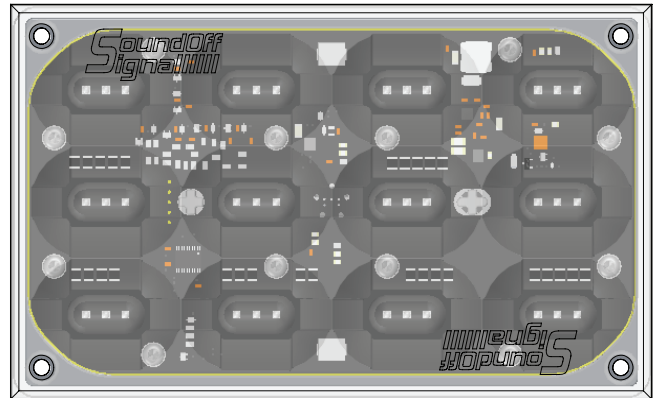

6x4 Tri-color Shown

Protected by U.S. Patent 10,703,260 and Patents Pending
<https://soundoffsignal.com/legal/patent-notification/>

WARNING

- HIGH CURRENT interconnects must be properly terminated. Poor crimp quality can cause heat build-up and fire. Follow the crimp connector manufacturer instructions.
- DO NOT install this product or route any wires in the Air Bag Deployment Zone. Refer to vehicle Owner's Manual for deployment zones.
- Do NOT use system to disconnect headlights, brake lights or other safety equipment.
- Unit may become hot to touch during normal operation.
- Failure to properly install connectors, fuses or wiring may cause vehicle failure or fire.
- Installation must only be performed by trained technician. Installer must determine vehicle wiring configuration and proper integration of system.
- Use proper wire gauge. All power wires connecting to positive (+) or negative (-) battery terminal or local chassis ground (-) must be sized to supply at least 125% of max. current and properly fused at power source.
- Install protective grommets when routing wire through firewall or metal.
- Petroleum/silicone based lubricants will cause the silicone lens to discolor.

DIMENSIONS 2

WARNING LIGHT OPTIONS 2

TECHNICAL SPECIFICATIONS 3

WIRING INFORMATION 4-7

QUICK MOUNT INSTALLATION 8

STUD MOUNT INSTALLATION 8

SCREW MOUNT INSTALLATION 9

RETENTION CLIP INSTRUCTIONS . . . 10

WARNING

ROUTE WIRES ONLY IN LOCATIONS THAT ARE NOT SUBJECTED TO POTENTIAL WEAR. MAKE SURE TO AVOID ROUTING WIRES IN THE DEPLOYMENT AREA OF YOUR AIR BAG. REFER TO YOUR VEHICLE'S OWNER'S MANUAL FOR AIRBAG DEPLOYMENT ZONES.



1.800.338.7337 / www.soundoffsignal.com

NOTICE:

Installers and users must comply with all applicable federal, state and local laws regarding use and installation of warning devices. *Improper use or installation may void warranty coverage. To review our Limited Warranty Statement & Return Policy for this or any SoundOff Signal product, visit our website at www.soundoffsignal.com/tech-services/returns/. If you have questions regarding this product, contact **Technical Services**, Monday - Friday, 8 a.m. to 5 p.m. ET at **1.800.338.7337** (press #4). Questions or comments that do not require immediate attention may be emailed to techservices@soundoffsignal.com.*

ENHANCING SAFETY THROUGH INNOVATION

DIMENSIONS & BEZEL INFORMATION:

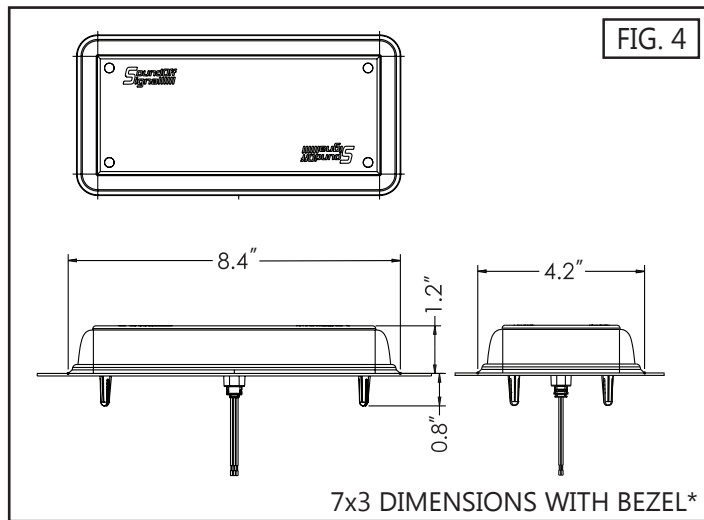
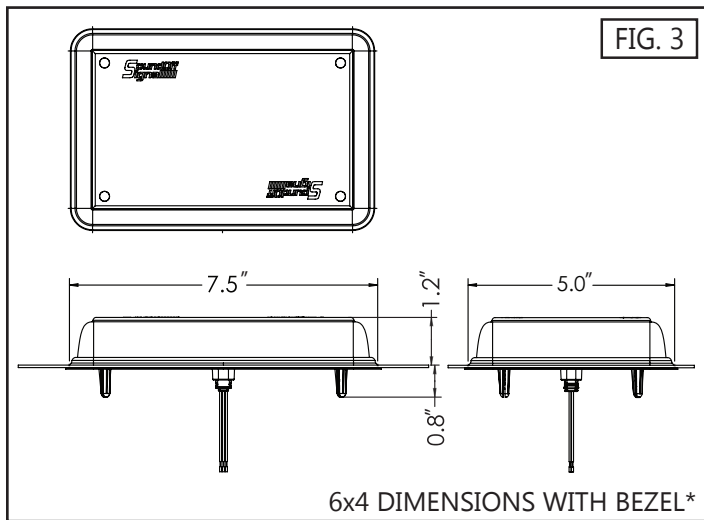
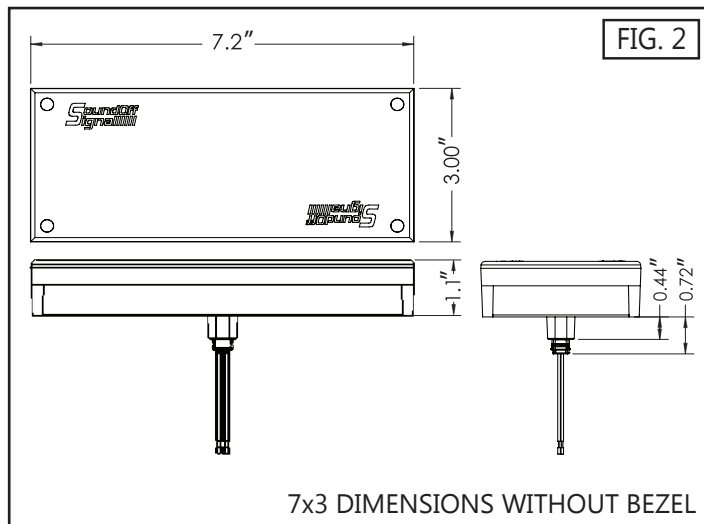
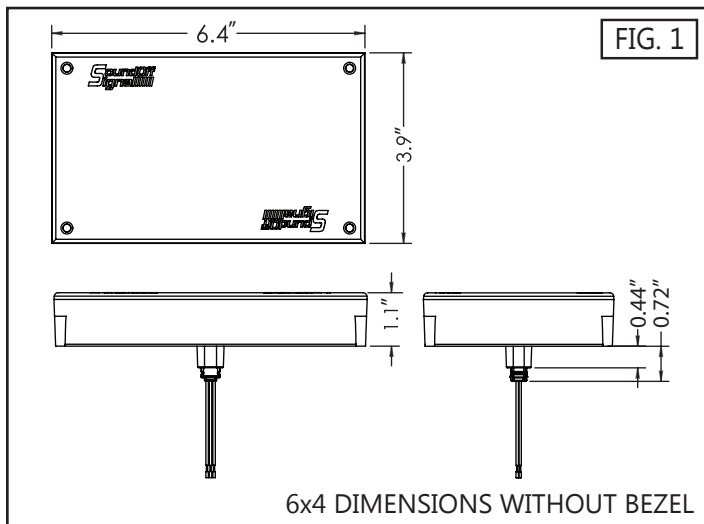

*Single Bezels are only compatible with Stud & Screw mount versions.

WARNING LIGHT OPTIONS:

7x3 & 6x4 LED OPTIONS

- Single Color
- Dual Color
- Split Color
- Tri-Color

7x3 & 6x4 LED COLOR OPTIONS

- Red
- Amber
- Blue
- White
- Green

7x3 & 6x4 CERTIFICATIONS

- SAEJ595
- California Title 13
- NFPA 1901-2009
- KKK-A-1822 (July 2021)

7x3 & 6x4 MOUNTING OPTIONS

- Quick Mount (*Not compatible with Bezel*)
- Stud Mount
- Screw Mount

7x3 & 6x4 AVAILABLE FLASH PATTERNS

- Double*
- Double 2*
- Inter-cycle
- Power Pulse*
- Q-switch
- Quad*
- Quad 2*
- Quad Pulse-pop*
- Quint*
- Random 1
- Random 2
- Road Runner*
- Steady-Burn Driver Title 13 Quad
- Steady-Burn/Road Runner
- Warp

*Certified Flash Patterns

PART NUMBERS (UNCONFIGURED)

- 7x3 - EMPSC0 XXX-X**
- 6x4 - EMPSB0 XXX-X**

**See SoundOff Signal configurator or sales representative for specific color, lens, and mounting options.

TECHNICAL SPECIFICATIONS: //

MPOWER® 7X3 & 6X4 WARNING LIGHT TECHNICAL SPECIFICATIONS				
	Input Voltage:		9-32Vdc	
	WARNING LIGHT CURRENT CONSUMPTION (Amps)			
	12.8Vdc		25.6Vdc	
	Peak	Average	Peak	Average
Red	1.55	0.78	0.78	0.39
Amber, Blue, Green, or White	1.90	0.95	0.95	0.48
AFTER POWER IS ON, touching the WHITE wire to the ground will allow you to change various settings on the module. (Refer to page 5)				

WIRING AND TABLE INFORMATION: //

OVER-VOLTAGE PROTECTION

When an over-voltage condition is detected, the module will flash an overvoltage warning pattern of 50mS ON/950mS OFF to alert of the overvoltage condition and protect the electronics from damage due to heat/voltage.

THERMAL COMPENSATION PROTECTION

The LED module is designed to provide maximum power output while providing protection to the electronic components by reducing the output power at extreme temperatures.

SYNC 2

Synchronizing the flashing of multiple light modules is accomplished by connecting the Green wires of different light modules together. Up to 24 light modules can be connected for synchronized flashing. All light module flash patterns must be set to the same flash pattern # to ensure proper operation. Refer to the Sequence Type section in Set-Up Table (page 7) to setup light modules to flash in alternate or simultaneous flash pattern. NOTE: Will NOT work with non-Sync 2 products such as Ghost, LED3, and 4 wire Intersector. WILL WORK with Sync 2 products nFORCE Secondary Lights, nFORCE FIT and 5 wire Intersector Lights.

WIRE HOOK-UP TABLE	
WIRE COLOR:	FUNCTION:
RED	Power (Primary)
BLACK	Ground
GREEN**	Sync2 *
WHITE to GROUND	Setup Wire (See pg. 6*)
WHITE to POWER	Function Wire
ORANGE	Power (Secondary)

- ** To sync multiple mPower lights, connect the Green wire from each light together.
- * Will NOT work w/ other sync products such as Ghost, LED3, & 4 wire Intersector w/external flasher
- * Will Work with Sync 2 products nFORCE Secondary Lights, nFORCE FIT and 5 wire Intersector Lights.

FLASH PATTERNS				CERTIFICATIONS		
PATTERN #	SINGLE COLOR	DUAL COLOR	TRI-COLOR	FLASHES PER MINUTE	HIGH POWER	LOW POWER
1	QUINT			70	SAE, KKK	SAE, KKK
2	WARP			360	NA	NA
3	INTER-CYCLE			-	NA	NA
4	DOUBLE			70	SAE, KKK	SAE, KKK
5	QUAD			80	SAE, NFPA, KKK	SAE, NFPA, KKK
6	POWER PULSE			180	SAE, NFPA, KKK	SAE, NFPA, KKK
7	ROAD RUNNER			118	SAE, CA13*, NFPA, KKK	SAE, CA13*, NFPA, KKK
8	Q-SWITCH			-	NA	NA
9	STEADY-BURN / ROADRUNNER (SEQUENCE TYPE 1: STEADY BURN, SEQUENCE TYPE 2: ROADRUNNER)			- / 118	NA	NA
10	STEADY-BURN DRIVER TITLE 13 QUAD (SEQUENCE TYPE 1: STEADY BURN, SEQUENCE TYPE 2: TITLE 13 QUAD)			- / 65	NA	NA
11	QUAD 2			67	SAE, KKK	SAE, KKK
12	DOUBLE 2			95	SAE, NFPA, KKK	SAE, NFPA, KKK
13	RANDOM 1			-	NA	NA
14	RANDOM 2			-	NA	NA
15	QUAD PULSE-POP			75	SAE, CA13*, NFPA, KKK	SAE, CA13*, NFPA, KKK

*CA13 AMBER is met in Low Power Only

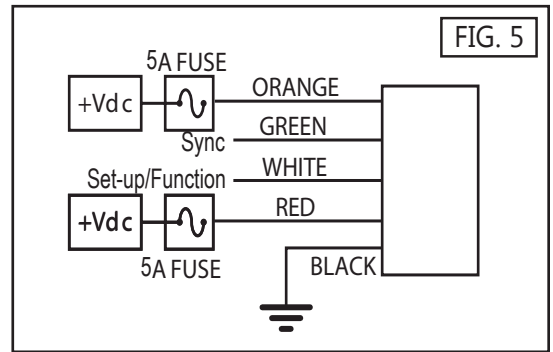

CERTIFICATION	APPLICABLE COLORS
SAEJ595	Red, Amber, Blue, White, Green
CALIFORNIA TITLE 13	Red, Amber, Blue
NFPA 1901-2009	Red, Amber, Blue, White
KKK-A-1822F (JULY 2021)	Red, Amber, Blue, White, Green

Lights are chassis-grounded. If you need to ground-switch the light, you must isolate the lights metal backing, heatsink, studs and/or screws from the body of the vehicle or use a relay.

WIRING AND TABLE INFORMATION (CONT.):

FUNCTION TABLES

The functional operation of the LED module can be changed while applying the +V to the Red wire with the Black wire connected to ground. When the light is flashing, momentarily connect the White wire to ground for >4S and <5S (light will go steady high, steady low, off, steady high, steady low) then release. The function table will now advance to the next table (table 1 to table 2, table 2 to table 3, table 3 to table 4, or table 4 to table 1. In the case that the custom table is programmed, the order is 1 to 2, 2 to 3, 3 to 4, or 4 to 7 (custom), and 7 to 1.) Repeat above process until required function table is active.

EXAMPLE:

If the light is using Function Table 2 with the Orange wire to power, which steady burns color 2, and you then apply the White wire to ground, to change the Function Table to number 3, this would cause the light to start flashing dual low power.

FUNCTION TABLE 1					
WIRE			LIGHT		
RED	ORANGE	WHITE	SINGLE	DUAL	TRI
+9-32V	-	-	FLASH	FLASH DUAL	FLASH TRI
-	+9-32V	-	CRUISE	STEADY COLOR 2	STEADY COLOR 3
+9-32V	+9-32V	-	FLASH	STEADY COLOR 2	STEADY COLOR 3
-	-	+9-32V	NO OP	NO OP	NO OP
+9-32V	-	+9-32V	LOW PWR FLASH	FLASH COLOR 1	FLASH COLOR 1
-	+9-32V	+9-32V	CRUISE	FLASH COLOR 2	FLASH COLOR 2
+9-32V	+9-32V	+9-32V	LOW PWR FLASH	FLASH DUAL	FLASH COLOR 3

FUNCTION TABLE 2					
WIRE			LIGHT		
RED	ORANGE	WHITE	SINGLE	DUAL	TRI
+9-32V	-	-	FLASH	FLASH COLOR 1	FLASH DUAL
-	+9-32V	-	STEADY COLOR 1	STEADY COLOR 2	STEADY COLOR 3
+9-32V	+9-32V	-	STEADY COLOR 1	STEADY COLOR 2	STEADY COLOR 3
-	-	+9-32V	NO OP	NO OP	NO OP
+9-32V	-	+9-32V	CRUISE	FLASH DUAL	FLASH TRI
-	+9-32V	+9-32V	STEADY COLOR 1	STEADY COLOR 2	STEADY COLOR 3
+9-32V	+9-32V	+9-32V	STEADY COLOR 1	STEADY COLOR 2	STEADY COLOR 3

FUNCTION TABLE 3					
WIRE			LIGHT		
RED	ORANGE	WHITE	SINGLE	DUAL	TRI
+9-32V	-	-	FLASH	FLASH DUAL	FLASH TRI
-	+9-32V	-	LOW PWR FLASH	FLASH DUAL LOW PWR	FLASH TRI LOW PWR
+9-32V	+9-32V	-	LOW PWR FLASH	FLASH DUAL LOW PWR	FLASH TRI LOW PWR
-	-	+9-32V	NO OP	NO OP	NO OP
+9-32V	-	+9-32V	LOW PWR FLASH	FLASH DUAL LOW PWR	FLASH TRI LOW PWR
-	+9-32V	+9-32V	LOW PWR FLASH	FLASH DUAL LOW PWR	FLASH TRI LOW PWR
+9-32V	+9-32V	+9-32V	LOW PWR FLASH	FLASH DUAL LOW PWR	FLASH TRI LOW PWR

FUNCTION TABLE 4					
WIRE			LIGHT		
RED	ORANGE	WHITE	SINGLE	DUAL	TRI
+9-32V	-	-	-	-	FLASH TRI
-	+9-32V	-	-	-	FLASH COLOR 1 & COLOR 2
+9-32V	+9-32V	-	-	-	FLASH COLOR 1 & COLOR 3
-	-	+9-32V	-	-	NO OP
+9-32V	-	+9-32V	-	-	FLASH COLOR 2 & COLOR 3
-	+9-32V	+9-32V	-	-	STEADY COLOR 3
+9-32V	+9-32V	+9-32V	-	-	FLASH TRI LOW PWR

AFTER SELECTION

The light will "wink" to indicate which of the new tables is selected. Custom table will "wink" 7 times.

WIRING AND TABLE INFORMATION (CONT.):

REMOTE MODE: For use with bluePRINT® system only

Connecting the Green wire to ground before applying power to the Red or Orange wires will place the LED module into remote mode and the light output color will be directly controlled by the input wires as shown below.

For Cruise mode or Low Power control of the LED module, the signal to the control wires must be 100 +/- 2Hz using the duty cycle inputs listed below to produce the light output.

MPOWER® 6x4 & 7X3 LED LIGHT REMOTE MODE FUNCTIONALITY							
RED WIRE	ORANGE WIRE	SINGLE COLOR		DUAL COLOR		TRI COLOR	
		COLOR SWAP = OFF	COLOR SWAP = ON	COLOR SWAP = OFF	COLOR SWAP = ON	COLOR SWAP = OFF	COLOR SWAP = ON
CRUISE	-	CRUISE COLOR 1	-	CRUISE COLOR 1	CRUISE COLOR 2	CRUISE COLOR 1	CRUISE COLOR 2
-	CRUISE	-	-	CRUISE COLOR 2	CRUISE COLOR 1	CRUISE COLOR 2	CRUISE COLOR 1
CRUISE	CRUISE	-	-	CRUISE COLOR 2	CRUISE COLOR 1	CRUISE COLOR 3	CRUISE COLOR 3
FLASH	-	FLASH COLOR 1	-	FLASH COLOR 1	FLASH COLOR 2	FLASH COLOR 1	FLASH COLOR 2
-	FLASH	-	-	FLASH COLOR 2	FLASH COLOR 1	FLASH COLOR 2	FLASH COLOR 1
FLASH	FLASH	-	-	FLASH COLOR 2	FLASH COLOR 1	FLASH COLOR 3	FLASH COLOR 3
STEADY ON	-	STEADY ON COLOR 1	-	STEADY ON COLOR 1	STEADY ON COLOR 2	STEADY ON COLOR 1	STEADY ON COLOR 2
-	STEADY ON	-	-	STEADY ON COLOR 2	STEADY ON COLOR 1	STEADY ON COLOR 2	STEADY ON COLOR 1
STEADY ON	STEADY ON	-	-	STEADY ON COLOR 2	STEADY ON COLOR 1	STEADY ON COLOR 3	STEADY ON COLOR 3
CRUISE	FLASH	-	-	FLASH COLOR 2/ CRUISE COLOR 1 DURING OFF CYCLE OF FLASH	FLASH COLOR 1/ CRUISE COLOR 2 DURING OFF CYCLE OF FLASH	-	-
CRUISE	STEADY ON	-	-	STEADY ON COLOR 2	STEADY ON COLOR 1	-	-
Flash	Steady ON	-	-	Steady ON Color 2	Steady ON Color 1	-	-

CRUISE MODE DUTY CYCLE (@ 100HZ)	
INPUT	LIGHT OUTPUT
40%	OFF
50%	5%
60%	10%

LOW POWER FLASH D.C. (@ 100HZ)	
INPUT	LIGHT OUTPUT
70%	30%
80%	40%
90%	50%

WIRING AND TABLE INFORMATION (CONT.):

COLOR SWAP

This function is only valid for dual and tri-color warning light modules and can only be changed when the light module is in a flashing mode (disabled for single color modules and when light module is operating in cruise or steady ON functions). When the light is flashing, momentarily connect the white wire to ground for >2S and <3S (light will go steady high, steady low, off) then release. The light module will switch between Color Swap OFF and Color Swap ON. When Color Swap is OFF, the 1st color will flash 1st on a dual/tri color pattern. When Color Swap is ON, the 2nd color will flash 1st on a dual/tri color pattern.

SIMULTANEOUS/ALTERNATE

This function can only be changed when the LED module is in a flashing mode (disabled in cruise or steady ON functions) and only has an effect when at least 2 LED modules have the green sync wire connected together. When the light is flashing, momentarily connect the white wire to ground for >3S and <4S (light will go steady high, steady low, off, steady high) then release. The light module will switch between Simultaneous and Alternate each time this sequence is done. To have light modules flash simultaneously, both light modules need to be set to the same sequence type (Set-Up Table). To have light modules flash alternately, the light modules need to be set to different sequence types (Set-Up Table).

ADVANCE PATTERN

Flash pattern can only be changed when the LED module is in a flashing mode (disabled in cruise or steady ON functions). When the light is flashing, momentarily connect the white wire to ground for >250mS and <1S (light will go steady high) then release. The flash pattern will advance to the next pattern. If the light module was at the last pattern, the pattern will reset to the 1st pattern.

BACKUP PATTERN

This function is only valid when the LED module is in a flashing mode (disabled in cruise or steady ON functions). When the light is flashing, momentarily connect the white wire to ground for >1S and < 2S (light will go steady high, steady low) then release. The flash pattern will backup to the previous pattern. If the light module was at the first pattern, the pattern will change to the last pattern on the list.

PATTERN RESET

This function is only valid when the LED module is in a flashing mode (disabled in cruise or steady ON functions). When the light is flashing, momentarily connect the white wire to ground for >5S and <6S (light will go steady high, steady low, off, steady high, steady low, off) then release. The flash pattern will reset to the 1st pattern in the list.

FACTORY RESET

This function is only valid when the LED module is in a flashing mode (disabled in cruise or steady ON functions). When the light is flashing, momentarily connect the white wire to ground for >6S and <7S (light will go steady high, steady low, off, steady high, steady low, off, steady high) then release. The LED module will reset to: pattern=1, Function Table=1, Color Swap=OFF, Simultaneous.

LOCKOUT CONFIGURATION WIRE

This function will disable the wire tap configuration mode that is activated by holding the white wire to ground. The lock out is activated by applying ground to the white wire for >7 seconds and <8 seconds per the table below. The function can be disabled by tapping the wire to ground and releasing 8 times within 5 seconds. The light will flash 8 times when the feature is enabled or disabled to notify the user of a setting change.

SETUP TABLE

SECONDS		USER INTERFACE	
FROM	TO	VISUAL FEEDBACK	ACTION TAKEN
0	1	STEADY-HIGH (60%)	FORWARD ONE PATTERN
1	2	STEADY-LOW (30%)	BACKWARD ONE PATTERN
2	3	OFF	COLOR SWAP (OFF OR ON)
3	4	STEADY - HIGH (60%)	SEQUENCE TYPE: SIMULTANEOUS OR ALTERNATE
4	5	STEADY - LOW (30%)	SEE FUNCTION TABLE
5	6	OFF	RESET TO PATTERN 1
6	7	STEADY-HIGH (60%)	FACTORY RESET (PATTERN 1, COLOR SWAP: OFF, SIMULTANEOUS) SEPARATE COLOR CONTROL: OFF
7	8	STEADY - LOW (30%)	LOCK OUT WHITE CONFIGURATION WIRE
If held longer than 8 seconds, the light will go back to flashing the current pattern and no action will be taken.			

QUICK MOUNT INSTALLATION: //

1. Drill a 3/4" wire hole (see **Fig. 7**).
2. Insert (4) Silicone Plugs into Light to Seal Screw Holes. (Use a 50% Isopropyl alcohol, 50% deionized water mix for lubrication if necessary).



3. Prep the back of the light and vehicle mount surfaces with 50% deionized water, 50% isopropyl alcohol wipe, and allow to dry.
4. Adhere VHB quick mount to the back of the light and press down firmly for 15 seconds on full surface.
5. Pull the wire harness through the vehicle wire hole and plug into the back of the light. Reference **page 10** for retention clip installation.
6. Lightly place the light against vehicle mount surface and check that the alignment is satisfactory. Once alignment is correct press firmly against light for 15 seconds to set VHB quick mount.

NOTE: Bezels will not work with the Quick Mount option.

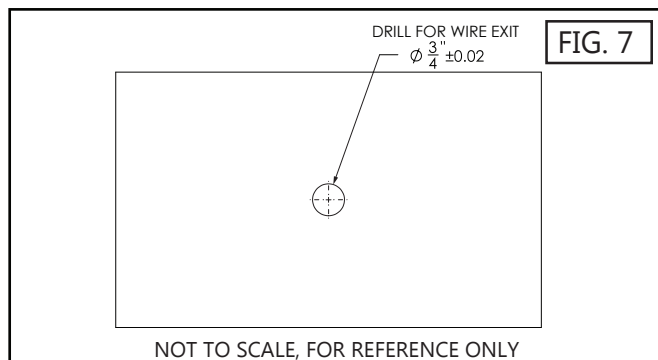
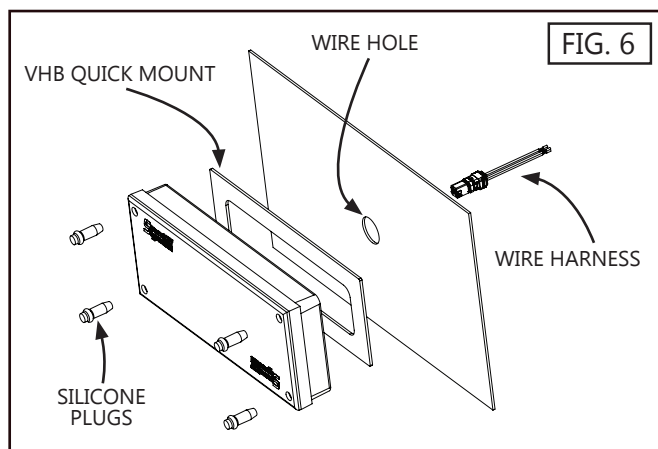

STUD MOUNT INSTALLATION: //

1. Drill (2) 1/4" holes to mount light. Drill 3/4" wire hole (see **Fig. 9**). The drill template shown is compatible with both the the 6x4 and 7x3 stud mount light.
2. Insert (4) Silicone Plugs into Light to Seal Screw Holes. (Use a 50% Isopropyl alcohol, 50% deionized water mix for lubrication if necessary).



3. Thread studs into the back of light.
4. Align the gasket to the mounting surface. Horizontal and vertical orientations are indicated on gasket for proper seal.
5. Place the bezel over gasket.
6. Place the light into bezel, press firmly to make sure bezel and gasket are tight against mounting surface.
7. Secure the light to mounting surface using (2) supplied nuts.

NOTE: Tighten until gasket is compressed. **DO NOT** over tighten and strip casting threads. **DO NOT USE POWER TOOLS TO TIGHTEN.**

8. Plug the wire harness into the back of the light. Reference **page 10** for retention clip installation.

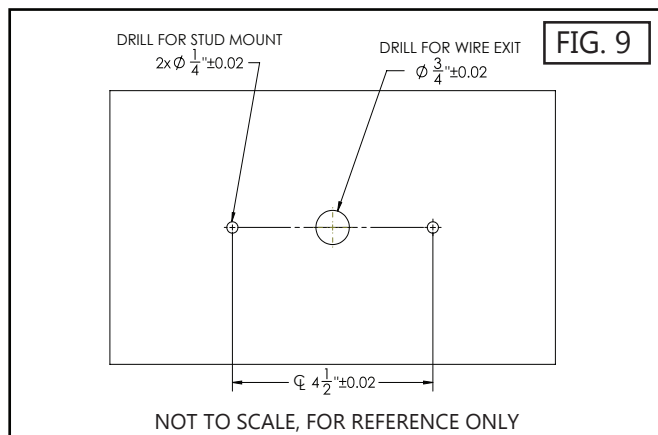
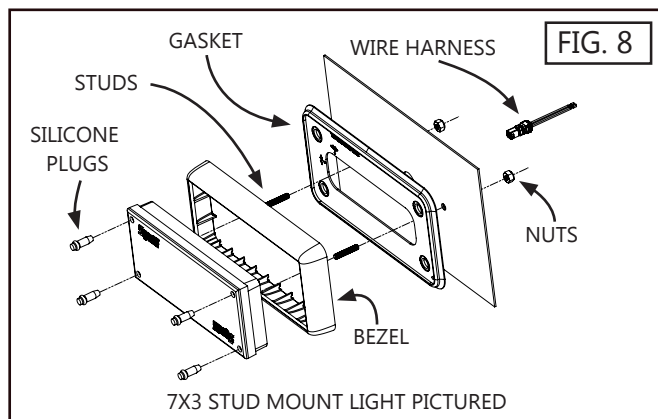

SCREW MOUNT INSTALLATION:

1. Drill (4) 5/16" holes to mount light. Drill 3/4" wire hole. See Fig. 11(7x3) or Fig. 12(6x4).
2. If a bezel is being used, place the light into the bezel.
3. Place the gasket on the back of the light and bezel (if used)

NOTE: Horizontal and vertical orientations indicated on gasket for proper seal.

4. Insert the (4) supplied screws into each screw hole in the light.
5. Place (4) flat washers over the screws on the back of the light.
6. Screw onto each fastener the (4) well nuts onto the back of the light. Tighten until snug.
7. Pull the wire harness through the opening and plug into the back of the light.
8. With the light assembly in hand, insert the well nuts into the (4) drilled holes. Fully seat to mounting surface.
9. Secure the light to mounting surface. While applying pressure on each fastener, tighten the (4) screws 7 full turns.

NOTE: Tighten until gasket is compressed. DO NOT over tighten.

10. Insert (4) Silicone Plugs into the light to seal screw holes. (Use a 50% Isopropyl alcohol, 50% deionized water mix for lubrication if necessary).

NOTE: Bezel required for any mounting not protected by intentionally recessed designed mounting locations.

DO NOT USE POWER DRIVER. .

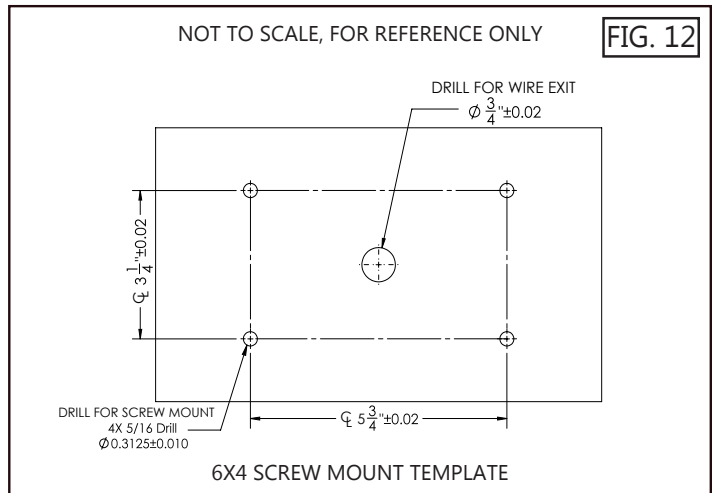
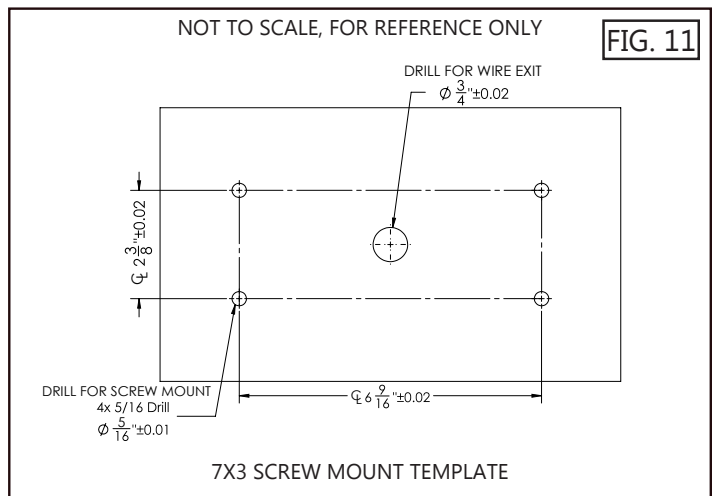
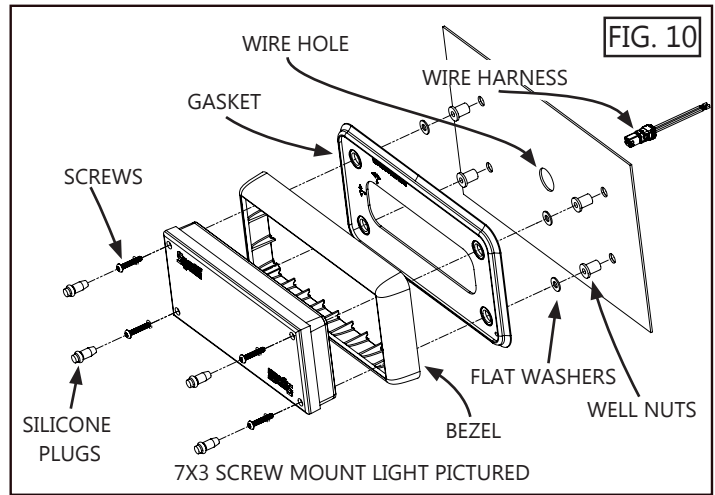

WARNING
 PETROLEUM/SILICONE BASED
 LUBRICANTS WILL CAUSE THE
 SILICONE LENS TO DISCOLOR.

RETENTION CLIP INSTRUCTIONS: ////////////////////////////////////

NOTE: In the event the harness needs to be disengaged from the light, these instructions can be used to reattach and apply the retention clip.

1. Plug harness into light housing, aligning tab to window, as shown in **Fig 13**.
2. Install the retainer clip over harness/light interface, inserting retainer into window, as shown in **Fig. 14**.
3. Press retainer clip's locking arm to snap closed.

