

# XtraFit<sup>®</sup> KIT

**nFORCE**  
NEXUS TECHNOLOGY

**MAGNUM**  
LED LIGHTBAR

**PNFLBK09: Fixed Mount w/Hook Strap & Thin Pad - nFORCE**  
**PEMG2K07: Premium Fixed Mount w/Hook Strap & Thin Pad - MAGNUM**

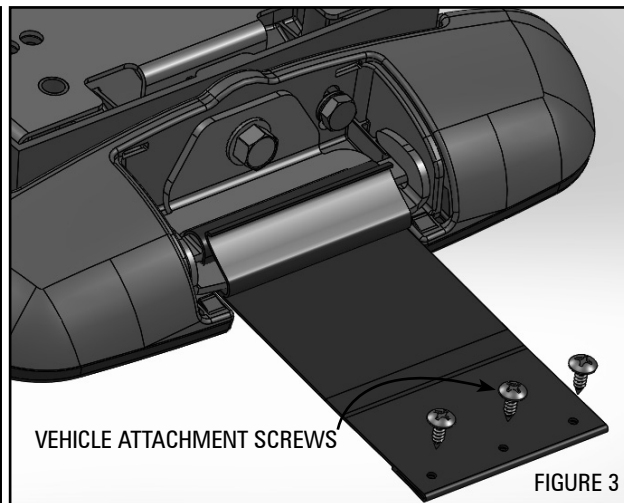
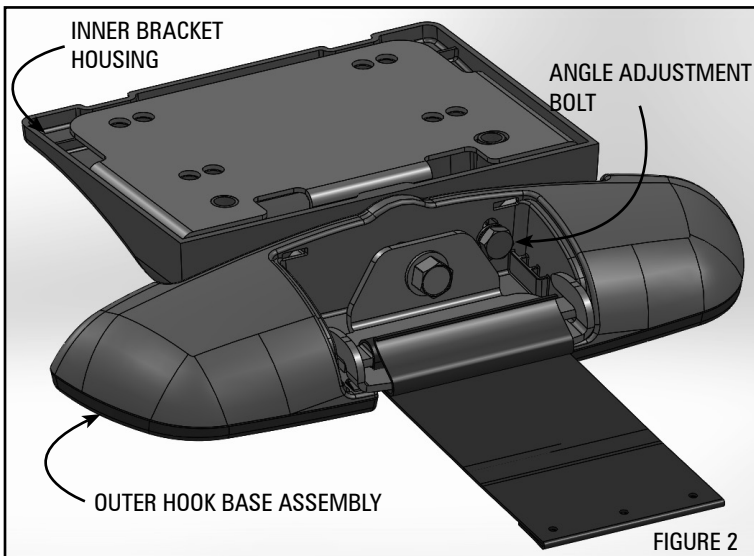
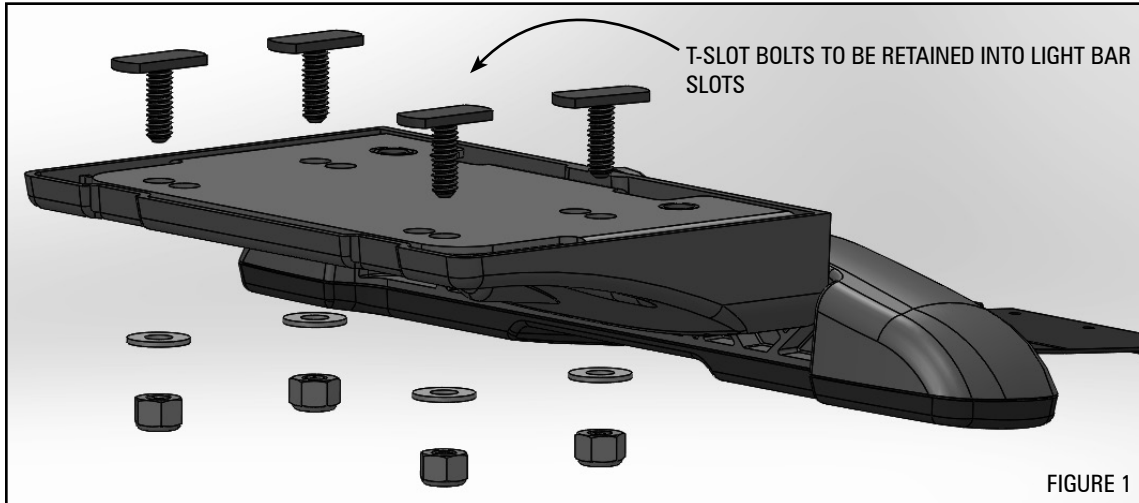

## INSTALLATION INSTRUCTIONS:

1. Install driver and passenger side hook assemblies onto the bottom of light bar using the (4) T-slot mounting bolts, washers and lock nuts. (Figure 1)
2. Adjust hook assemblies to be on the most outward edge of vehicle. Too much horizontal webbing going across the top of the vehicle will result in additional lifting of lightbar at high speeds.
3. Tighten the (4) T-slot mounting bolts to secure hook assemblies to the bottom of the light bar. Tighten to the torque details below:

Due to different vehicle construction and mounting locations, the torque levels for connecting hooks to the lightbar foot may be different based on the vehicle.

A. Minimum requirement for torque should be 10 IN/LB, with a maximum level of 45 IN/LB.\*

B. When installing the bolts connecting the hook to the lightbar foot, monitor both the lightbar and roof of the vehicle.

C. Tighten to ensure there is no movement of the lightbar or foot by ensuring there is no movement either side to side, or front to rear after the torque has been done.

The lightbar must be securely mounted to the vehicle for safe operation.

\*Deflection of the lightbar and/or the roof of the vehicle may occur when torquing the bolts connecting the hook to the lightbar foot. Any deflection should be kept at a minimum to avoid damage to the lightbar or vehicle.

**NOTE: As always, it is recommended to check the integrity of mounted lightbars on a daily basis to ensure secure attachment to the vehicle for continued safe operation.**

## **⚠ WARNING**

Route wires only in locations that are not subjected to potential wear. Make sure to avoid routing wires in the deployment area of your air bag. Refer to your vehicle's owner's manual for airbag deployment zone.

## NOTICE:

Installers and users must comply with all applicable federal, state and local laws regarding use and installation of warning devices.

*Improper use or installation may void warranty coverage.*

To review our Limited Warranty Statement & Return Policy for this or any SoundOff Signal product, visit our website at [www.soundoffsignal.com/tech-services/returns/](http://www.soundoffsignal.com/tech-services/returns/). If you have questions regarding this product, contact **Technical Services**, Monday - Friday, 8 a.m. to 5 p.m. or after hours 5 p.m. to 8 p.m. ET at 1.800.338.7337 (press #4). Questions or comments that do not require immediate attention may be emailed to [techservices@soundoffsignal.com](mailto:techservices@soundoffsignal.com).

SUPERIOR CUSTOMER RELATIONSHIPS. SMARTLY DESIGNED LIGHTING & ELECTRONIC SOLUTIONS.

**SoundOff**  
**Signal**

1.800.338.7337 / [www.soundoffsignal.com](http://www.soundoffsignal.com)

# XtraFit<sup>®</sup> KIT

PNFLBK09: Fixed Mount w/Hook Strap & Thin Pad - nFORCE

PEMG2K07: Premium Fixed Mount w/Hook Strap & Thin Pad - MAGNUM

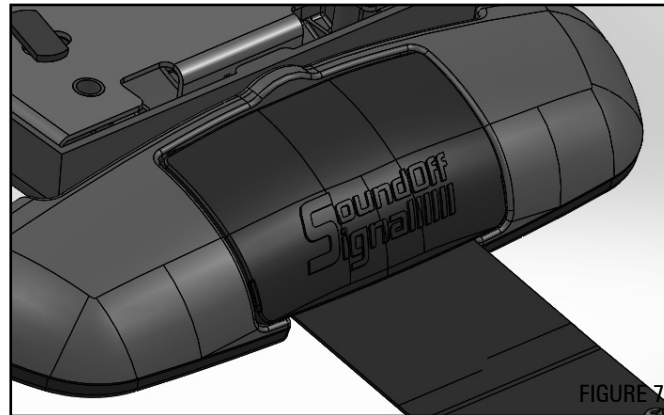
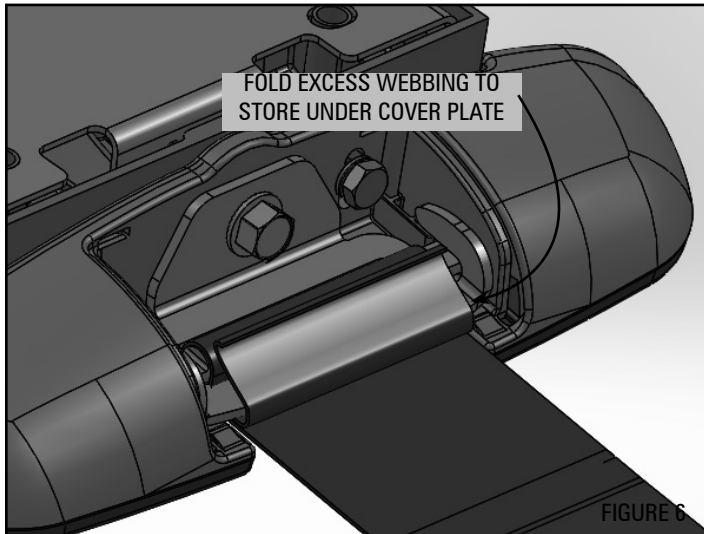
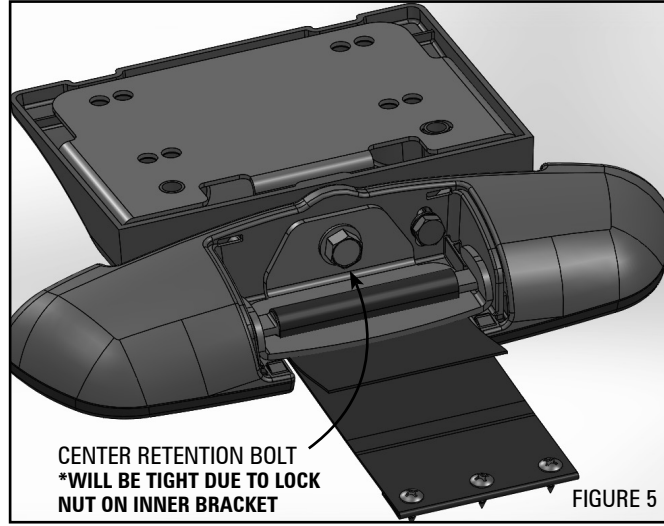
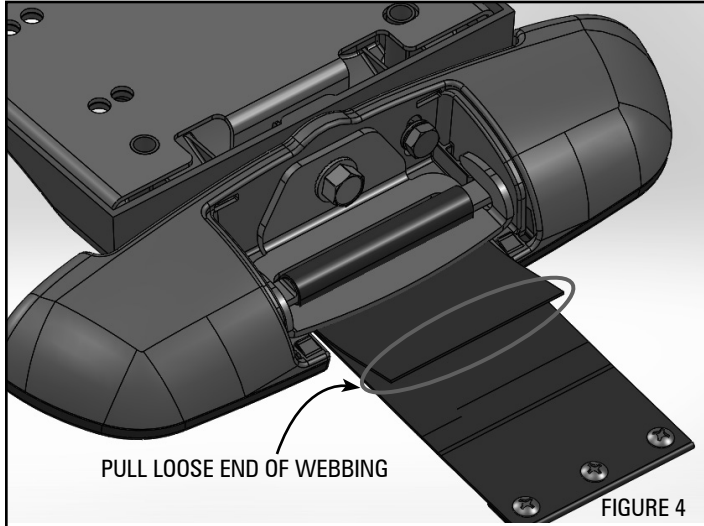

**NOTE: THE XTRAFIT HOOK KIT IS RATED TO 75 MPH**

## INSTALLATION INSTRUCTIONS (CONT.):

4. Adjust the horizontal angle of the bar by loosening the 1/4" angle adjustment bolt, adjusting the bar to be horizontal between the inner bracket housing and the outer hook base and then retightening 1/4" angle adjustment bolt. (Figure 2, Page 1)

5. Using the three vehicle attachment screws secure the webbing to the inside edge of vehicle rail. (Figure 3, Page 1)

**NOTE: DO NOT USE SELF-TAPPING SCREWS FOR WEB ATTACHMENT TO VEHICLE!**

6. After webbing is secure to vehicle pull the adjustable end of the webbing until tight to vehicle roof. (Figure 4)

7. After webbing is tight against vehicle, tighten center retention bolt fully to pull webbing and lightbar tight onto vehicle. Webbing bracket should be fully seated against back wall of outer hook base. **Note: If light bar and webbing needs to be further tighten, loosen center retention bolt to allow additional webbing to be pulled thru webbing bracket, retightening center retention bolt to pull webbing tight.** (Figure 5)

8. Once drivers and passenger side hook assemblies are fully engaged and tight to vehicle the excess webbing can be folded up and stored under hook kit cover plate. (Figure 6)

9. To install hook kit cover plate engage the top tabs of cover into mounting slots on outer hook base unit and engage snap features on the bottom corners of cover. (Figure 7)

## NOTICE:

Installers and users must comply with all applicable federal, state and local laws regarding use and installation of warning devices.

*Improper use or installation may void warranty coverage.*

To review our Limited Warranty Statement & Return Policy for this or any SoundOff Signal product, visit our website at [www.soundoffsignal.com/tech-services/returns/](http://www.soundoffsignal.com/tech-services/returns/). If you have questions regarding this product, contact **Technical Services**, Monday - Friday, 8 a.m. to 5 p.m. or after hours 5 p.m. to 8 p.m. ET at 1.800.338.7337 (press #4). Questions or comments that do not require immediate attention may be emailed to [techservices@soundoffsignal.com](mailto:techservices@soundoffsignal.com).

SUPERIOR CUSTOMER RELATIONSHIPS. SMARTLY DESIGNED LIGHTING & ELECTRONIC SOLUTIONS.

**SoundOff  
Signal** 

1.800.338.7337 / [www.soundoffsignal.com](http://www.soundoffsignal.com)