

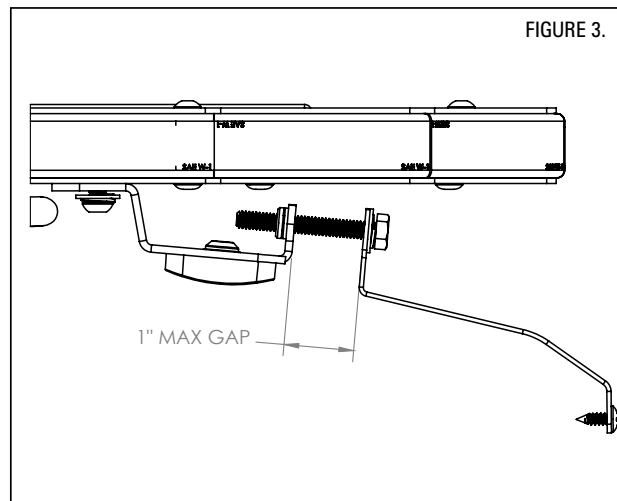

PMPLBK04 - LB XTRA LOW FIXED HEIGHT MOUNT

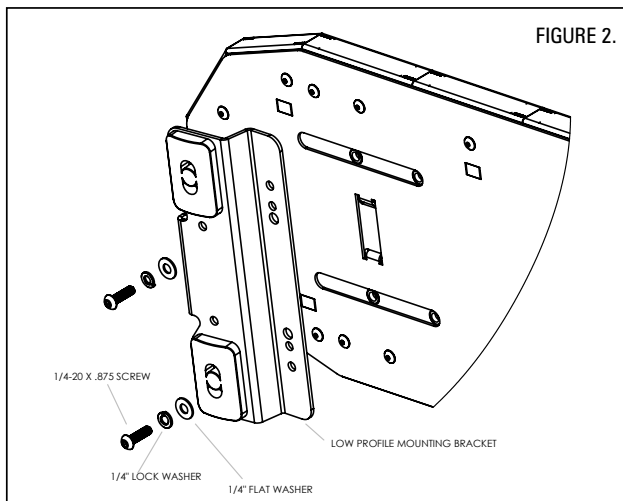
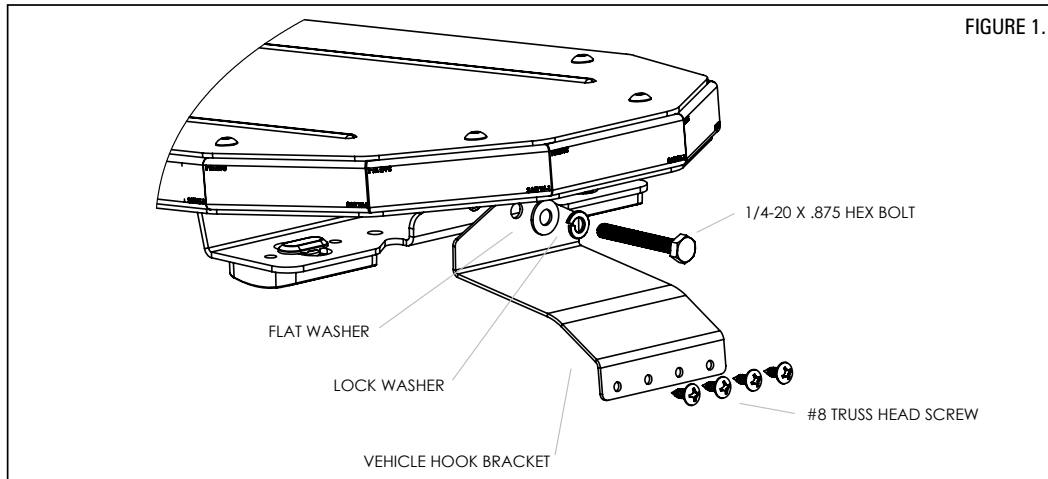

INSTALLATION INSTRUCTIONS:

1. Insert 1/4-20 x 8.75 screw into 1/4" lock washer and 1/4", insert into the middle hole in the mounting bracket.
2. Tighten until snug, as adjustments may need to be done.
3. Temporarily, place lightbar on the vehicle roof. It is recommended that the bar is positioned about the center of the vehicle, adjust the brackets for even spacing. Leave about 1" of space between hook bracket and mounting foot bracket, as shown.
4. Tighten the 1/4-20 screws to the lightbar, torque details below:

Due to different vehicle construction and mounting locations, the torque levels for connecting hooks to the lightbar foot may be different based on the vehicle.

A. Minimum requirement for torque should be 10 IN/LB, with a maximum level of 45 IN/LB.*

B. When installing the bolts connecting the hook to the lightbar foot, monitor both the lightbar and roof of the vehicle.

C. Tighten to ensure there is no movement of the lightbar or foot by ensuring there is no movement either side to side, or front to rear after the torque has been done.

The lightbar must be securely mounted to the vehicle for safe operation.

*Deflection of the lightbar and/or the roof of the vehicle may occur when torquing the bolts connecting the hook to the lightbar foot. Any deflection should be kept at a minimum to avoid damage to the lightbar or vehicle.

NOTE: As always, it is recommended to check the integrity of mounted lightbars on a daily basis to ensure secure attachment to the vehicle for continued safe operation.

5. Install the vehicle specific hook brackets using supplied 1/4-20 x 2.5 hex head bolt into mounting bracket, as shown. A nut is attached to the bracket to prevent turning and improve ease of installation.
6. Using the vehicle specific hook bracket as a template, drill 4 pilot holes using a #30 drill on each side of the vehicle.
7. Secure each vehicle specific hook bracket by using the 8 supplied #8 x 1/2" truss head sheet metal screws, 4 per side.
8. Tighten the 1/4-20 hex bolt until the lightbar is snug and no side-to-side, or fore and aft, movement occurs. Tighten 50 in/lbs. max.

NOTICE:

Installers and users must comply with all applicable federal, state and local laws regarding use and installation of warning devices.

Improper use or installation may void warranty coverage.

To review our Limited Warranty Statement & Return Policy for this or any SoundOff Signal product, visit our website at www.soundoffsignal.com/tech-services/returns/. If you have questions regarding this product, contact **Technical Services**, Monday - Friday, 8 a.m. to 5 p.m. or after hours 5 p.m. to 8 p.m. ET at 1.800.338.7337 (press #4). Questions or comments that do not require immediate attention may be emailed to techservices@soundoffsignal.com.

**SoundOff
Signal**

1.800.338.7337 / www.soundoffsignal.com

SUPERIOR CUSTOMER RELATIONSHIPS. SMARTLY DESIGNED LIGHTING & ELECTRONIC SOLUTIONS.