

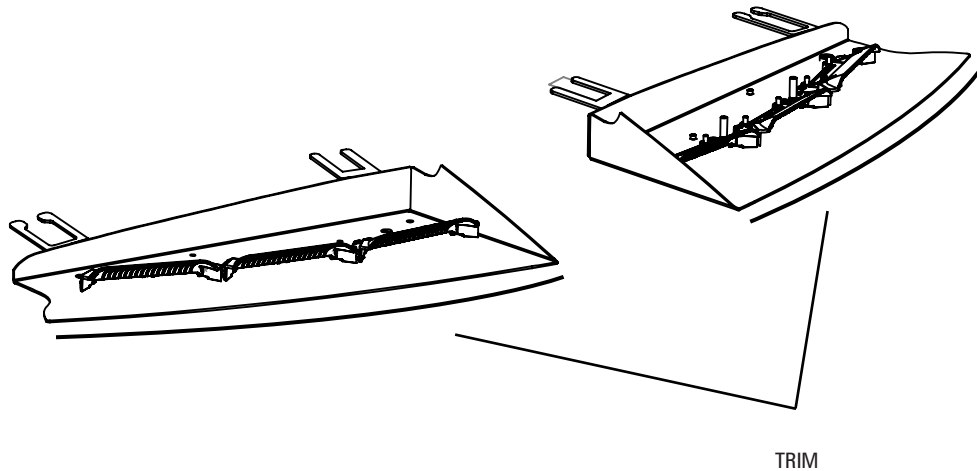

nFORCE LED Interior Lightbar 2013-2018 Ford Fusion



⚠ WARNING

- HIGH CURRENT interconnects must be properly terminated. Poor crimp quality can cause heat build-up and fire. Follow crimp connector manufacturer instructions.
- DO NOT install this product or route any wires in the Air Bag Deployment Zone. Refer to vehicle Owner's Manual for deployment zones.
- Do NOT use system to disconnect headlights, brake lights or other safety equipment.
- Unit may become hot to touch during normal operation.
- Failure to properly install connectors, fuses or wiring may cause vehicle failure or fire.
- Installation must only be performed by trained technician. Installer must determine vehicle wiring configuration and proper integration of system.
- Use proper wire gauge. All power wires connecting to positive (+) or negative (-) battery terminal or local chassis ground (-) must be sized to supply at least 125% of max. current and properly fused at power source.
- Install protective grommets when routing wire through firewall or metal.



1.800.338.7337 / www.soundoffsignal.com

1

INSTALLATION:

1. Attach brackets to shrouds using the supplied Phillips Head screws. Leave connection loose for adjustability during vehicle installation.
2. Remove all visor clips (2) and visor attachment brackets (2) per manufacturer's recommendations.
3. Place Mounting brackets underneath visor clip and attachment brackets and re-assemble to vehicle. For visor clips on the interior most part of the vehicle, a long screw may be required for re-assembly.
4. Adjust shrouds fore or aft so that shrouds are level and trim is touching window.
5. Tighten all screws to secure in place.
6. Route Wires to switching equipment. Be mindful to keep wire routing away from airbag deployment zones.

OPERATION:

SEE 'ELECTRICAL INSTALLATION' SECTION OF THE nFORCE LED INTERIOR LIGHTBAR INSTALLATION PACKET.

⚠ WARNING

This product contains high intensity LED devices.
To prevent eye damage, DO NOT stare into the light beam at close range.

NOTICE:

Installers and users must comply with all applicable federal, state and local laws regarding use and installation of warning devices.

Improper use or installation may void warranty coverage.

To review our Limited Warranty Statement & Return Policy for this or any SoundOff Signal product, visit our website at www.soundoffsignal.com/tech-services/returns/.

If you have questions regarding this product, contact **Technical Services**, Monday - Friday, 8 a.m. to 5 p.m. ET at 1.800.338.7337 (press #4).

Questions or comments that do not require immediate attention may be emailed to techservices@soundoffsignal.com.

ENHANCING SAFETY THROUGH INNOVATION