

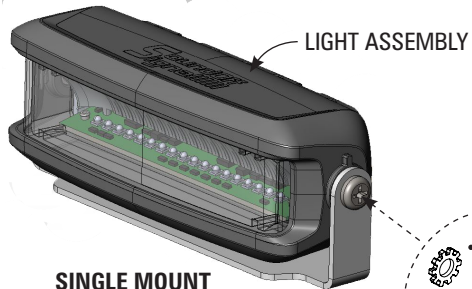

**SAE J595 CLASS 1 DECK/ GRILL MOUNTS**

ENFSGS(XXX) - SINGLE  
ENFDGS(XXX) - DUAL



**SINGLE MOUNT VERSION**

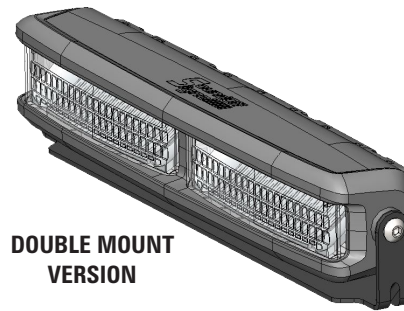
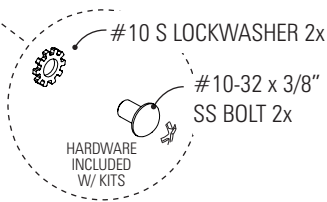

**DOUBLE MOUNT VERSION**

TECHNICAL SPECIFICATIONS		
DECK/ GRILL MOUNT nFORCE		
Single Mount Dimensions:	5.0"L x 1.88"H x 1.82"D	
Double Mount Dimensions:	9.50"L x 1.88"H x 1.82"D	
Input Voltage:	10 - 16 Vdc or 10 - 30 Vdc *	
CURRENT CONSUMPTION PER MODULE		
	10-16 Vdc	10-30 Vdc *
6 LED Single 12 LED Dual & 18 LED Tri-Color	<1.0A @12.8 Vdc	<0.6A @25.6 Vdc
9 LED Single Color	<1.5A @ 12.8 Vdc	<0.9A @ 25.6 Vdc
12 LED Single Color	<2.0A @12.8 Vdc	<1.2A @ 25.6 Vdc

\* - Special Order

**INSTALLATION:**

1) Establish a flat position on the vehicle. Drill 3/16" holes in the center of the mounting locations. Note: 2 bolts are desired for the single mount and 4 bolts for the double mount attachments (not included with hardware kit). See page 6 for hole spacing.

**INFORMATION FOR nFORCE SECONDARY:**

WIRE HOOK-UP TABLE	
WIRE COLOR:	FUNCTION:
ORANGE OR RED	Power
BLACK	Ground
BLUE OR GREEN**	Sync2 *
YELLOW OR WHITE to GROUND	Wire Function -See page 4-
YELLOW OR WHITE to POWER	Function Wire
RED/WHITE OR ORANGE/WHITE	Power

\*\* To sync multiple nFORCE lights, connect the Green and/or Blue wires from each light together.

\* Will NOT work w/ other sync products such as Ghost, LED3, & Intersector.

**⚠ WARNING**

- HIGH CURRENT interconnects must be properly terminated. Poor crimp quality can cause heat build-up and fire. Follow crimp connector manufacturer instructions.
- DO NOT install this product or route any wires in the Air Bag Deployment Zone. Refer to vehicle Owner's Manual for deployment zones.
- Unit may become hot to touch during normal operation.
- Failure to properly install connectors, fuses or wiring may cause vehicle failure or fire.
- Installation must only be performed by trained technician. Installer must determine vehicle wiring configuration and proper integration of system.
- Use proper wire gauge. All power wires connecting to positive (+) or negative (-) battery terminal or local chassis ground (-) must be sized to supply at least 125% of max. current and properly fused at power source.
- Install protective grommets when routing wire through firewall or metal.



**NOTICE:**

Installers and users must comply with all applicable federal, state and local laws regarding use and installation of warning devices.

Improper use or installation may void warranty coverage. To review our Limited Warranty Statement & Return Policy for this or any SoundOff Signal product, visit our website at [www.soundoffsignal.com/sales-support](http://www.soundoffsignal.com/sales-support). If you have questions regarding this product, contact **Technical Services**, Monday - Friday, 8 a.m. to 5 p.m. at 1.800.338.7337 (press #4 to skip the automated message). Questions or comments that do not require immediate attention may be emailed to [techservices@soundoffsignal.com](mailto:techservices@soundoffsignal.com).

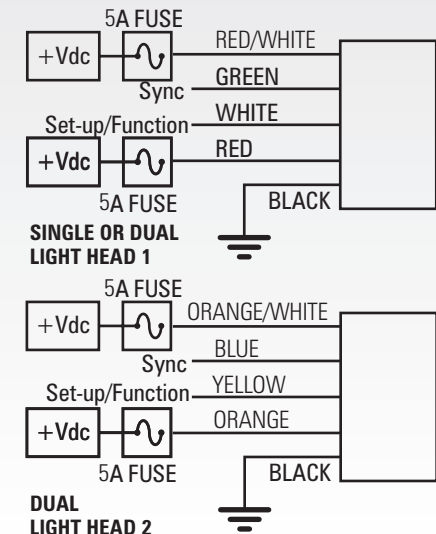

1.800.338.7337 / [www.soundoffsignal.com](http://www.soundoffsignal.com)



**OVER-VOLTAGE PROTECTION**

When an over-voltage condition is detected, the module will flash an over-voltage warning pattern of 50mS ON/950mS OFF to alert of the over-voltage condition and protect the electronics from damage due to heat/voltage.

**THERMAL COMPENSATION PROTECTION**

The LED module is designed to provide maximum power output while providing protection to the electronic components by reducing the output power at extreme temperatures.

**SYNC 2**

Synchronizing the flashing of multiple light modules is accomplished by connecting the Green and/or Blue wires of different light modules together. Up to 24 light modules can be connected for synchronized flashing. All light module flash patterns must be set to the same flash pattern # to ensure proper operation. Refer to the Sequence Type section in Set-Up Table to setup light modules to flash in alternate or simultaneous flash pattern. NOTE: Will NOT work with non-Sync 2 products such as Ghost, LED3, and Single Color Intersector.

FLASH PATTERNS			
PATTERN #	SINGLE COLOR	DUAL COLOR	TRI-COLOR
1		QUINT	
2		WARP	
3		INTER-CYCLE	
4		DOUBLE	
5		QUAD	
6		POWER PULSE	
7		ROAD RUNNER	
8		Q-SWITCH	
9		STEADY-BURN / ROADRUNNER (SEQUENCE TYPE 1: STEADY BURN, SEQUENCE TYPE 2: ROADRUNNER)	
10		STEADY-BURN DRIVER TITLE 13 QUAD (SEQUENCE TYPE 1: STEADY BURN, SEQUENCE TYPE 2: TITLE 13 QUAD)	
11		QUAD 2	
12		DOUBLE 2	
13			RANDOM 1
14			RANDOM 2





**FUNCTION TABLES**

Changing the function table is only enabled when the LED module is in a flashing mode (disabled in cruise or steady ON functions). The functional operation of the LED module can be changed while applying the +V to the Red or Orange wire with the black wire connected to ground. When the light is flashing, momentarily connect the White or Yellow wire to ground for >4S and <5S (light will go steady high, steady low, off, steady high, steady low) then release. The function table will now advance to the next table (table 1 to table 2, table 2 to table 3, or table 3 to table 1). Repeat above process until required function table is active.

FUNCTION TABLE 1					
WIRE			LIGHT		
RED (SGL) ORANGE (DUAL)	R/W (SGL) O/W (DUAL)	WHT (SGL) YELLOW (DUAL)	SINGLE	DUAL	TRI
+12V			FLASH	FLASH DUAL	FLASH TRI
	+12		CRUISE	STEADY CLR 2	STEADY CLR 3
+12V	+12V		FLASH	STEADY CLR 2	STEADY CLR 3
		+12V	NO OP	NO OP	NO OP
+12V		+12V	LOW PWR FLASH	FLASH CLR 1	FLASH CLR 1
	+12V	+12V	CRUISE	FLASH CLR 2	FLASH CLR 2
+12V	+12V	+12V	LOW PWR FLASH	FLASH CLR 1 & 2	FLASH CLR 3

FUNCTION TABLE 2					
WIRE			LIGHT		
RED (SGL) ORANGE (DUAL)	R/W (SGL) O/W (DUAL)	WHT (SGL) YELLOW (DUAL)	SINGLE	DUAL	TRI
+12V			FLASH	FLASH CLR 1	FLASH CLR 1 & 2
+12V		+12V	CRUISE	FLASH CLR 1 & 2	FLASH CLR 1, 2 & 3
	+12V		STEADY CLR 1	STEADY CLR 2	STEADY CLR 3
	+12V	+12V	STEADY CLR 1	STEADY CLR 2	STEADY CLR 3
+12V	+12V	+12V	STEADY CLR 1	STEADY CLR 2	STEADY CLR 3
		+12V	NO OP	NO OP	NO OP

FUNCTION TABLE 3					
WIRE			LIGHT		
RED (SGL) ORANGE (DUAL)	R/W (SGL) O/W (DUAL)	WHT (SGL) YELLOW (DUAL)	SINGLE	DUAL	TRI
+12V			FLASH	FLASH DUAL	FLASH CLR 1, 2 & 3
	+12V		FLASH LOW PWR	FLASH CLR 1 & 2 LOW PWR	FLASH CLR 1, 2 & 3 LOW PWR
+12V	+12V		FLASH LOW PWR	FLASH COLOR 1 & 2 LOW PWR	FLASH CLR 1, 2 & 3 LOW PWR
		+12V	NO OP	NO OP	NO OP
+12V		+12V	FLASH LOW PWR	FLASH COLOR 1 & 2 LOW PWR	FLASH CLR 1, 2 & 3 LOW PWR
	+12V	+12V	FLASH LOW PWR	FLASH COLOR 1 & 2 LOW PWR	FLASH CLR 1, 2 & 3 LOW PWR
+12V	+12V	+12V	FLASH LOW PWR	FLASH COLOR 1 & 2 LOW PWR	FLASH CLR 1, 2 & 3 LOW PWR





**COLOR SWAP**

This function is only valid for dual and tri-color light modules and can only be changed when the light module is in a flashing mode (disabled for single color modules and when light module is operating in cruise or steady ON functions). When the light is flashing, momentarily connect the white or yellow wire to ground for >2S and <3S (light will go steady high, steady low, off) then release. The light module will switch between Color Swap OFF and Color Swap ON. When Color Swap is OFF, the 1st color will flash 1st on a dual/tri color pattern. When Color Swap is ON, the 2nd color will flash 1st on a dual/tri color pattern.

**SIMULTANEOUS/ALTERNATE**

This function can only be changed when the LED module is in a flashing mode (disabled in cruise or steady ON functions) and only has an effect when at least 2 LED modules have the green sync wire connected together. When the light is flashing, momentarily connect the white or yellow wire to ground for >3S and <4S (light will go steady high, steady low, off, steady high) then release. The light module will switch between Simultaneous and Alternate each time this sequence is done. To have light modules flash simultaneously, both light modules need to be set to the same sequence type (Set-Up Table). To have light modules flash alternately, the light modules need to be set to different sequence types (Set-Up Table).

**ADVANCE PATTERN**

Flash pattern can only be changed when the LED module is in a flashing mode (disabled in cruise or steady ON functions). When the light is flashing, momentarily connect the white or yellow wire to ground for >250mS and <1S (light will go steady high) then release. The flash pattern will advance to the next pattern. If the light module was at the last pattern, the pattern will reset to the 1st pattern.

**BACKUP PATTERN**

This function is only valid when the LED module is in a flashing mode (disabled in cruise or steady ON functions). When the light is flashing, momentarily connect the white or yellow wire to ground for >1S and < 2S (light will go steady high, steady low) then release. The flash pattern will backup to the previous pattern. If the light module was at the first pattern, the pattern will change to the last pattern on the list.

**PATTERN RESET**

This function is only valid when the LED module is in a flashing mode (disabled in cruise or steady ON functions). When the light is flashing, momentarily connect the white or yellow wire to ground for >5S and <6S (light will go steady high, steady low, off, steady high, steady low, off) then release. The flash pattern will reset to the 1st pattern in the list.

**FACTORY RESET**

This function is only valid when the LED module is in a flashing mode (disabled in cruise or steady ON functions). When the light is flashing, momentarily connect the white or yellow wire to ground for >6S and <7S (light will go steady high, steady low, off, steady high, steady low, off, steady high) then release. The LED module will reset to: pattern=1, Function Table=1, Color Swap=OFF, Simultaneous.

SETUP TABLE			
SECONDS		USER INTERFACE	
FROM	TO	VISUAL FEEDBACK	ACTION TAKEN
0	1	STEADY-HIGH (60%)	FORWARD ONE PATTERN
1	2	STEADY-LOW (30%)	BACKWARD ONE PATTERN
2	3	OFF	COLOR SWAP (OFF OR ON )
3	4	STEADY - HIGH (60%)	SEQUENCE TYPE: SIMULTANEOUS OR ALTERNATE
4	5	STEADY - LOW (30%)	SEE FUNCTION TABLE
5	6	OFF	RESET TO PATTERN 1
6	7	STEADY-HIGH (60%)	FACTORY RESET (PATTERN 1, COLOR SWAP: OFF, SIMULTANEOUS) SEPARATE COLOR CONTROL: OFF
<p><b>If held longer than 7 seconds, the light will go back to flashing the current pattern and no action will be taken.</b></p>			



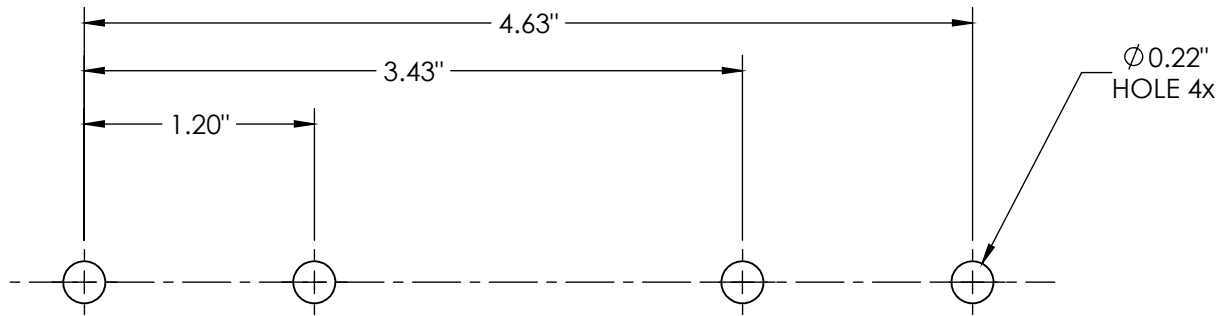

DOUBLE MOUNT DECK/ GRILLE TEMPLATE

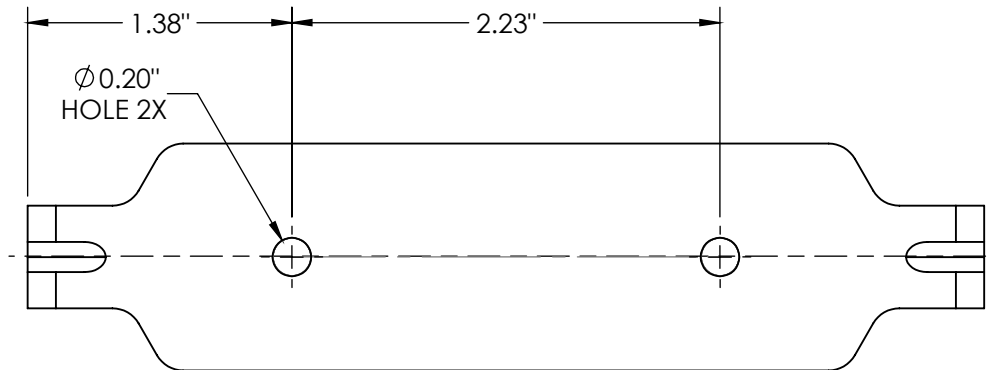

SINGLE MOUNT DECK/ GRILLE TEMPLATE



**REMOTE MODE: FOR USE WITH bluePRINT SYSTEM ONLY**

Connecting the Green or Blue wire to ground before applying power to the Orange, Orange/White, Red or Red/White wires will place the LED module into remote mode and the light output color will be directly controlled by the input wires as shown below.

For Cruise mode or Low Power control of the LED module, the signal to the control wires must be 100 +/- 2Hz using the duty cycle inputs listed below to produce the light output.

nFORCE Secondary LED Light Remote Mode Functionality							
Red or Orange Wire	Red/Wht or Orange/Wht Wire	Single Color		Dual Color		Tri Color	
		Color Swap=OFF	Color Swap=ON	Color Swap=OFF	Color Swap=ON	Color Swap=OFF	Color Swap=ON
Cruise	-	Cruise Color 1		Cruise Color 1	Cruise Color 2	Cruise Color 1	Cruise Color 2
-	Cruise			Cruise Color 2	Cruise Color 1	Cruise Color 2	Cruise Color 1
Cruise	Cruise			Cruise Color 2	Cruise Color 1	Cruise Color 3	Cruise Color 3
Flash	-	Flash Color 1		Flash Color 1	Flash Color 2	Flash Color 1	Flash Color 2
-	Flash			Flash Color 2	Flash Color 1	Flash Color 2	Flash Color 1
Flash	Flash			Flash Color 2	Flash Color 1	Flash Color 3	Flash Color 3
Steady ON	-	Steady ON Color 1		Steady ON Color 1	Steady ON Color 2	Steady ON Color 1	Steady ON Color 2
-	Steady ON			Steady ON Color 2	Steady ON Color 1	Steady ON Color 2	Steady ON Color 1
Steady ON	Steady ON			Steady ON Color 2	Steady ON Color 1	Steady ON Color 3	Steady ON Color 3
Cruise	Flash			Flash Color 2/Cruise Color 1 during OFF cycle of Flash	Flash Color 1/Cruise Color 2 during OFF cycle of Flash		
Cruise	Steady ON			Steady ON Color 2	Steady ON Color 1		
Flash	Steady ON			Steady ON Color 2	Steady ON Color 1		

Cruise Mode Duty Cycle (@ 100Hz)	
Input	Light Output
40%	OFF
50%	5%
60%	10%

Low Power Flash D.C. (@ 100Hz)	
Input	Light Output
70%	30%
80%	40%
90%	50%

