

intersector™

by SoundOff Signal

INTERSECTOR LED LIGHT SURFACE MOUNT

- ENT3B3(xxx) - BLACK HOUSING
- ENT3C3(xxx) - CHROME HOUSING
- ENT3W3(xxx) - WHITE HOUSING
- PNT3DGBB - DECK / GRILLE BRACKET - BLACK

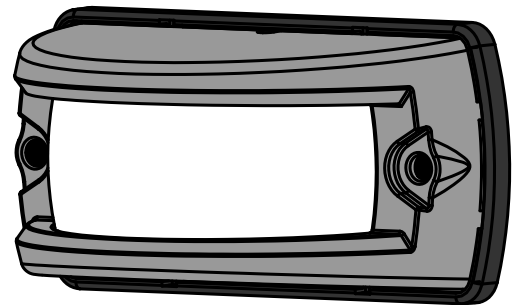

WARNING

- HIGH CURRENT interconnects must be properly terminated. Poor crimp quality can cause heat build-up and fire. Follow the crimp connector manufacturer instructions.
- DO NOT install this product or route any wires in the Air Bag Deployment Zone. Refer to vehicle Owner's Manual for deployment zones.
- Do NOT use system to disconnect headlights, brake lights or other safety equipment.
- Unit may become hot to touch during normal operation.
- Failure to properly install connectors, fuses or wiring may cause vehicle failure or fire.
- Installation must only be performed by trained technician. Installer must determine vehicle wiring configuration and proper integration of system.
- Use proper wire gauge. All power wires connecting to positive (+) or negative (-) battery terminal or local chassis ground (-) must be sized to supply at least 125% of max. current and properly fused at power source.
- Install protective grommets when routing wire through firewall or metal.
- Petroleum/silicone based lubricants will cause the silicone lens to discolor.

DIMENSIONS / TECHNICAL SPECIFICATIONS 2

SURFACE MOUNT INSTALL 3

DECK / GRILLE BRACKET INSTALL 3

ELECTRICAL INSTALLATION / INFORMATION . . . 4 - 7

WARRANTY INFORMATION 8

 **WARNING**

ROUTE WIRES ONLY IN LOCATIONS THAT ARE NOT SUBJECTED TO POTENTIAL WEAR. MAKE SURE TO AVOID ROUTING WIRES IN THE DEPLOYMENT AREA OF YOUR AIR BAG. REFER TO YOUR VEHICLE'S OWNER'S MANUAL FOR AIRBAG DEPLOYMENT ZONES.



Scan for the latest version of the instruction sheet



1.800.338.7337 / www.soundoffsignal.com

NOTICE:

Installers and users must comply with all applicable federal, state and local laws regarding use and installation of warning devices. *Improper use or installation may void warranty coverage. To review our Limited Warranty Statement & Return Policy for this or any SoundOff Signal product, visit our website at www.soundoffsignal.com/tech-services/returns/. If you have questions regarding this product, contact **Technical Services**, Monday - Friday, 8 a.m. to 5 p.m. ET at 1.800.338.7337 (press #4). Questions or comments that do not require immediate attention may be emailed to techservices@soundoffsignal.com.*

ENHANCING SAFETY THROUGH INNOVATION

INTERSECTOR SURFACE MOUNT
ENGLISH 0000JL 0823 REV A

INTERSECTOR DIMENSIONS / SPECIFICATIONS: //

OPERATION:

For details on operation see page with 'Flash Patterns' table on page 4.

TECHNICAL SPECIFICATIONS				
Single Mount Dimensions:	2.9" (74 mm) W x 1.9" (48 mm) H x 2.9" (74 mm) D			
Input Voltage:	9-32Vdc			
SINGLE / DUAL COLOR CURRENT CONSUMPTION (Amps)				
	12.8Vdc		25.6Vdc	
	Peak	Average	Peak	Average
Red	1.00	0.60	0.50	0.30
Amber, Blue, Green or White	1.30	0.80	0.65	0.40
TRI COLOR CURRENT CONSUMPTION (Amps)				
	12.8Vdc		25.6Vdc	
	Peak	Average	Peak	Average
Red	0.77	0.46	0.36	0.22
Amber, Blue, Green or White	1.00	0.60	0.50	0.30

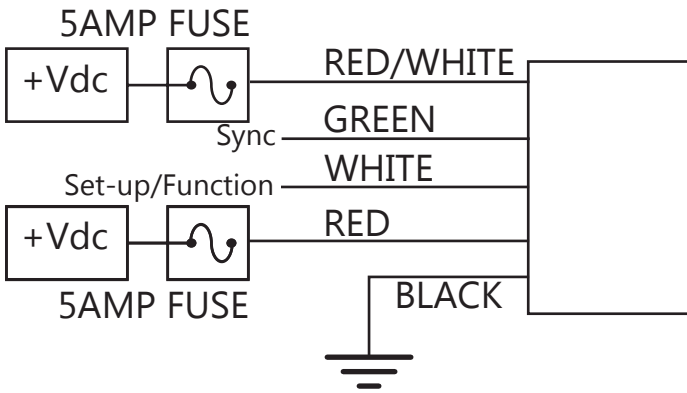

WIRE HOOK-UP TABLE	
WIRE COLOR:	FUNCTION:
RED	Table pg. 5
BLACK	Ground
GREEN**	Sync2 or Remote Node Function*
WHITE to GROUND	Wire Function See Table pg. 4
WHITE to POWER	Table pg. 5
RED/WHITE	Table pg. 5

** To sync multiple Intersector, mpower® or nFORCE® lights connect the green wire from each light together.

*Will NOT work w/ other sync products such as Ghost®, LED3, & 4-wire Intersector.



IMPORTANT:

Supply power through a 5AMP fuse. For Flashing mode, refer to function tables 1,2 and 3 on page 3. For slave/ Remote Node functionality such as when connected to Blueprint, permanently connect the Green wire to ground. Refer to Remote Node functionality table on page 5. Insulate all connections.

SURFACE MOUNT INSTALLATION:

Surface Mount (FIG. 1)

1. Establish a position on the vehicle on a level surface. Orient the light output level on the horizon.
2. Use the gasket provided as a template to mark locations of wire and mounting screws
3. Use a 5/8" diameter drill for the wire holes
4. Size pilot holes for mounting screws appropriately.
5. Fasten light using bezel and mounting screws. Do not torque mounting screws beyond 20 in - lbs.

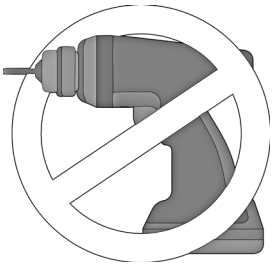

DO NOT USE POWER TOOLS TO TIGHTEN

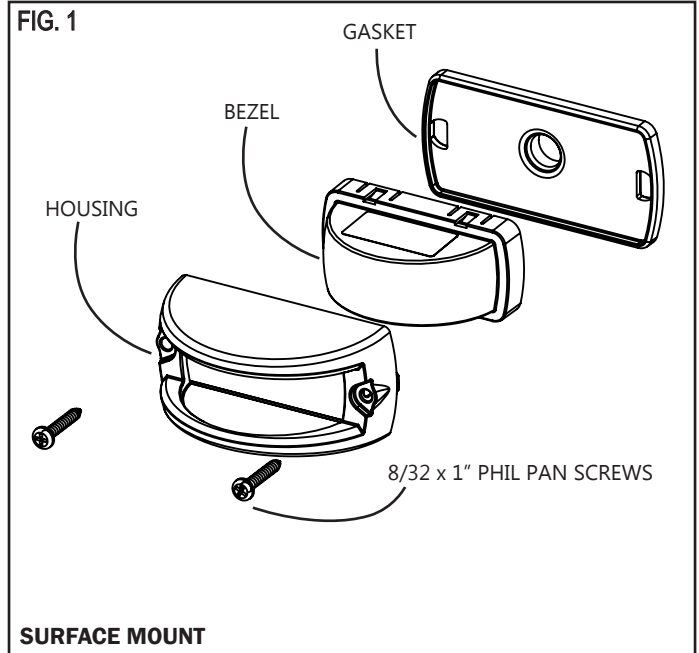

DECK / GRILLE BRACKET INSTALLATION:

Deck / Grille Bracket (Sold Separately) (FIG. 2)

1. Slide wire from Bezel through center access hole in the gasket and bracket.
2. Next, position the Housing over the Bezel and align the holes with the bracket.
3. Lastly, using the supplied 8-32 x 1" screws fasten the assembly lightly. Do not torque mounting screws beyond 20 in - lbs.
4. Establish a position on the vehicle on a level surface. Orient the light output level on the horizon.
5. Use the bracket provided as a template to mark locations of mounting screws.
6. Size pilot holes for mounting screws appropriately.
7. Fasten light using bezel and mounting screws. Do not torque mounting screws beyond 20 in - lbs.

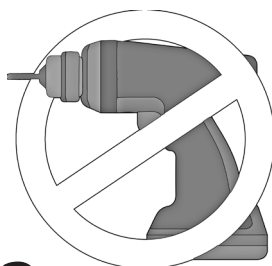

DO NOT USE POWER TOOLS TO TIGHTEN

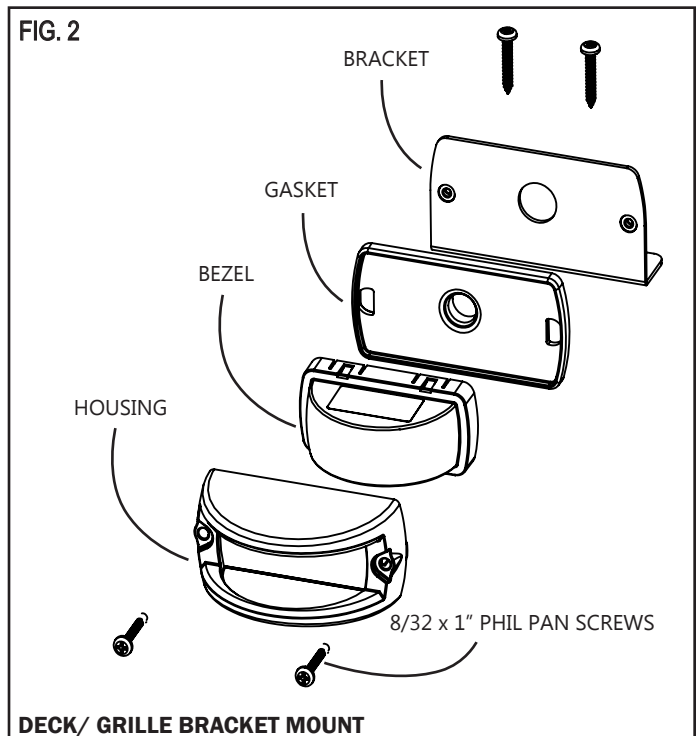

ELECTRICAL INSTRUCTIONS:

ADVANCE PATTERN

Flash pattern can only be changed when the LED module is in a flashing mode (disabled in cruise or steady ON functions). When the light is flashing, momentarily touch the white wire to ground for >250ms and <1s (light will go steady high) then release. The flash pattern will advance to the next pattern. If the light module was at the last pattern, the pattern will reset to the 1st pattern.

BACKUP PATTERN

This function is only valid when the LED module is in a flashing mode (disabled in cruise or steady ON functions). When the light is flashing, momentarily touch the white wire to ground for >1s and < 2s (light will go steady high, steady low) then release. The flash pattern will backup to the previous pattern. If the light module was at the first pattern, the pattern will change to the last pattern on the list.

COLOR SWAP

This function is only valid for dual color light modules and can only be changed when the light module is in a flashing mode (disabled for single color modules and when light module is operating in cruise or steady ON functions). When the light is flashing, momentarily touch the white wire to ground for >2s and <3s (light will go steady high, steady low, off) then release. The light module will switch between Color Swap OFF and Color Swap ON. When Color Swap is OFF, the 1st color will flash 1st on a dual color pattern. When Color Swap is ON, the 2nd color will flash 1st on a dual color pattern.

SIMULTANEOUS/ALTERNATE

This function can only be changed when the LED module is in a flashing mode (disabled in cruise or steady ON functions) and only has an effect when at least 2 LED modules have the green sync wire connected together.

When the light is flashing, momentarily touch the white wire to ground for >3s and <4s (light will go steady high, steady low, off, steady high) then release. The light module will switch between Simultaneous and Alternate each time this sequence is done. To have light modules flash simultaneously, both light modules need to be set to the same sequence type (Set-Up Table). To have light modules flash alternately, the light modules need to be set to different sequence types (Set-Up Table).

PATTERN RESET

This function is only valid when the LED module is in a flashing mode (disabled in cruise or steady ON functions). When the light is flashing, momentarily touch the white wire to ground for >5s and <6s (light will go steady high, steady low, off, steady high, steady low, off) then release. The flash pattern will reset to the 1st pattern in the list.

FACTORY RESET

This function is only valid when the LED module is in a flashing mode (disabled in cruise or steady ON functions). When the light is flashing, momentarily touch the white wire to ground for >6S and <7S (light will go steady high, steady low, off, steady high, steady low, off, steady high) then release. The LED module will reset to: pattern=1, Function Table=1, Color Swap=OFF, Simultaneous.

LOCKOUT CONFIGURATION WIRE

This function will disable the wire tap configuration mode that is activated by holding the white wire to ground. The lock out is activated by applying ground to the white wire for >7 seconds and <8 seconds per the table below. The function can be disabled by tapping the wire to ground and releasing 8 times within 5 seconds. The light will flash 8 times when the feature is enabled or disabled to notify the user of a setting change.

SETUP TABLE

SECONDS		USER INTERFACE	
FROM	TO	VISUAL FEEDBACK	ACTION TAKEN
0	1	STEADY-HIGH (60%)	FORWARD ONE PATTERN
1	2	STEADY-LOW (30%)	BACKWARD ONE PATTERN
2	3	OFF	COLOR SWAP (OFF OR ON)
3	4	STEADY - HIGH (60%)	SEQUENCE TYPE: SIMULTANEOUS OR ALTERNATE
4	5	STEADY - LOW (30%)	SEE FUNCTION TABLE
5	6	OFF	RESET TO PATTERN 1
6	7	STEADY-HIGH (60%)	FACTORY RESET (PATTERN 1, COLOR SWAP: OFF, SIMULTANEOUS) SEPARATE COLOR CONTROL: OFF
7	8	STEADY - LOW (30%)	LOCK OUT WHITE CONFIGURATION WIRE
If held longer than 8 seconds, the light will go back to flashing the current pattern and no action will be taken.			

ELECTRICAL INSTRUCTIONS CONTINUED:

FUNCTION TABLES

Changing the function table is only enabled when the LED module is in a flashing mode (disabled in cruise or steady ON functions). The functional operation of the LED module can be changed while applying the +V to the Red wire with the black wire connected to ground.

When the light is flashing, momentarily connect the White wire to ground for >4S and <5S (light will go steady high, steady low, off, steady high, steady low) then release. The function table will now advance to the next table (table 1 to table 2, table 2 to table 3, or table 3 to table 1). Repeat above process until required function table is active.

FUNCTION TABLE 1					
WIRE			LIGHT		
RED	R/W	WHT	SINGLE	DUAL	TRI
+9-32V			FLASH	FLASH DUAL	FLASH TRI
	+9-32V		CRUISE	STEADY CLR 2	STEADY CLR 3
+9-32V	+9-32V		FLASH	STEADY CLR 2	STEADY CLR 3
		+9-32V	NO OP	NO OP	NO OP
+9-32V		+9-32V	LOW PWR FLASH	FLASH CLR 1	FLASH CLR 1
	+9-32V	+9-32V	CRUISE	FLASH CLR 2	FLASH CLR 2
+9-32V	+9-32V	+9-32V	LOW PWR FLASH	FLASH DUAL	FLASH CLR 3

FUNCTION TABLE 2					
WIRE			LIGHT		
RED	R/W	WHT	SINGLE	DUAL	TRI
+9-32V			FLASH	FLASH CLR 1	FLASH DUAL
+9-32V		+9-32V	CRUISE	FLASH DUAL	FLASH TRI
	+9-32V		STEADY CLR 1	STEADY CLR 2	STEADY CLR 3
	+9-32V	+9-32V	STEADY CLR 1	STEADY CLR 2	STEADY CLR 3
+9-32V	+9-32V	+9-32V	STEADY CLR 1	STEADY CLR 2	STEADY CLR 3
		+9-32V	NO OP	NO OP	NO OP
+9-32V	+9-32V		STEADY CLR 1	STEADY CLR 2	STEADY CLR 3

FUNCTION TABLE 3					
WIRE			LIGHT		
RED	R/W	WHT	SINGLE	DUAL	TRI
+9-32V			FLASH	FLASH DUAL	FLASH TRI
	+9-32V		FLASH LOW PWR	FLASH DUAL LOW PWR	FLASH TRI LOW PWR
+9-32V	+9-32V		FLASH LOW PWR	FLASH DUAL LOW PWR	FLASH TRI LOW PWR
		+9-32V	NO OP	NO OP	NO OP
+9-32V		+9-32V	FLASH LOW PWR	FLASH DUAL LOW PWR	FLASH TRI LOW PWR
	+9-32V	+9-32V	FLASH LOW PWR	FLASH DUAL LOW PWR	FLASH TRI LOW PWR
+9-32V	+9-32V	+9-32V	FLASH LOW PWR	FLASH DUAL LOW PWR	FLASH TRI LOW PWR

ELECTRICAL INSTRUCTIONS CONTINUED:

REMOTE MODE: FOR USE WITH bluePRINT SYSTEM ONLY

Connecting the Green wire to ground before applying power to the Red or Red/White wires will place the LED module into remote mode and the light output color will be directly controlled by the input wires as shown below.

Intersector® Secondary LED Light Remote Mode Functionality							
Red Wire	Red/White Wire	Single Color		Dual Color		Tri Color	
		Color Swap=OFF	Color Swap=ON	Color Swap=OFF	Color Swap=ON	Color Swap=OFF	Color Swap=ON
Cruise	-	Cruise Color 1		Cruise Color 1	Cruise Color 2	Cruise Color 1	Cruise Color 2
-	Cruise			Cruise Color 2	Cruise Color 1	Cruise Color 2	Cruise Color 1
Cruise	Cruise			Cruise Color 2	Cruise Color 1	Cruise Color 3	Cruise Color 3
Flash	-	Flash Color 1		Flash Color 1	Flash Color 2	Flash Color 1	Flash Color 2
-	Flash			Flash Color 2	Flash Color 1	Flash Color 2	Flash Color 1
Flash	Flash			Flash Color 2	Flash Color 1	Flash Color 3	Flash Color 3
Steady ON	-	Steady ON Color 1		Steady ON Color 1	Steady ON Color 2	Steady ON Color 1	Steady ON Color 2
-	Steady ON			Steady ON Color 2	Steady ON Color 1	Steady ON Color 2	Steady ON Color 1
Steady ON	Steady ON			Steady ON Color 2	Steady ON Color 1	Steady ON Color 3	Steady ON Color 3
Cruise	Flash			Flash Color 2/Cruise Color 1 during OFF cycle of Flash	Flash Color 1/Cruise Color 2 during OFF cycle of Flash		
Cruise	Steady ON			Steady ON Color 2	Steady ON Color 1		
Flash	Steady ON			Steady ON Color 2	Steady ON Color 1		

Cruise and Low Power Modes

For Cruise mode or Low Power control of the LED module, the signal to the control wires must be 100 +/- 2Hz using the duty cycle inputs listed below to produce the light output.

Cruise Mode Duty Cycle (@ 100Hz)	
Input	Light Output
40%	OFF
50%	5%
60%	10%

Low Power Flash D.C. (@ 100Hz)	
Input	Light Output
70%	30%
80%	40%
90%	50%

WARRANTY & RETURN GOODS PROCEDURE

WARNING MESSAGES - PLEASE READ:

WARNING - DRILLING ANY HOLES INTO THE INTERSECTOR LIGHT IS NOT RECOMMENDED! THE RISK OF DAMAGING INTERNAL COMPONENTS AND THE RESULTING FAILURE OF THE INTERSECTOR LIGHT WILL VOID ANY WARRANTY OF THIS PRODUCT.

WARNING - CARE MUST BE TAKEN WHEN DRILLING THROUGH THE VEHICLE NOT TO DRILL INTO ANY EXISTING WIRING CHECK BOTH SIDES OF THE MOUNTING SERVICE PRIOR TO DRILLING. DE-BURR ANY HOLES AND REMOVE ANY METAL SHARDS OR REMNANTS. INSTALL GROMMETS INTO ALL WIRE PASSAGE HOLES.

WARNING - ROUTE WIRES ONLY IN LOCATIONS THAT ARE NOT SUBJECTED TO POTENTIAL WEAR. MAKE SURE TO AVOID ROUTING WIRES IN THE DEPLOYMENT AREA OF YOUR AIR BAG. REFER TO YOUR VEHICLE OWNER'S MANUAL FOR AIR BAG DEPLOYMENT ZONES.

WARNING - ALL CUSTOMER SUPPLIED POWER WIRES CONNECTING TO THE POSITIVE (+) OR NEGATIVE (-) BATTERY TERMINAL OR LOCAL CHASSIS GROUND (-) MUST BE SIZED TO SUPPLY AT LEAST 125% OF THE MAXIMUM CURRENT AND PROPERLY FUSED AT THE POWER SOURCE WITH APPROPRIATELY RATED FUSE.

WARRANTY RETURN PROCESS:

Please scan QR code or visit <https://soundoffsignal.com/support-page/returns/>.



Alternatively contact your SoundOff Signal Sales Representative, Customer Services staff or our Technical Department (800.338.7337) for a RMA #, Return Merchandise Authorization Number.

The following information is required for issuance of the RMA #:

- Reason for returning the product*
- Address where replacement product is to be shipped*
- Telephone number where you may be reached*
- SoundOff Signal invoice number on which product was purchased**
- SoundOff Signal part number and serial number**
- E-mail address where RMA # should be e-mailed**
- Fax number where RMA # should be faxed**

* RMA # will not be given without this information.

** If available, please provide this information.

SoundOff Signal will NOT accept returns without an RMA #. Each RMA # is good for only one (1) return and will expire (30) days after the date it was issued. Products must be shipped back to SoundOff Signal and the RMA # clearly marked on the outside of the package near the shipping label. Please use the following address on your shipping label:

SoundOff Signal
ATTN: RMA # / Technical Services
3900 Central Parkway
Hudsonville, MI 49426

WARRANTY EXCLUSIONS:

Shipping & Handling, labor and service fees are non-refundable. SoundOff Signal is not liable for any damage due to installation or personal injury as a result of using SoundOff Signal product.

WARRANTY FORFEITURE:

Warranty will not be granted if the Warranty Return Policy & Procedure rules are not strictly followed. Physical damage resulting from customer abuse will void warranty. Warranty will also be voided if any SoundOff Signal and/or manufacturer serial tags, product stickers, seals, or the like, are removed, altered or tampered with. Returned product that is damaged by shipping via the RMA # procedure is not the responsibility of SoundOff Signal.

Document effective date on cover and below supersedes previously dated policies and statements.

There are no other warranties, expressed or implied, including, but not limited to, any implied merchantability or fitness for a particular use. SoundOff Signal reserves the right to modify this warranty statement at any time; or to discontinue, modify, or upgrade any products of its manufacture with design improvements without prior notice.