

100N/100J SERIES SPEAKER BRACKET (NO DRILL) CAPABLE OF HOLDING UP TO TWO SPEAKERS FOR THE DODGE DURANGO PURSUIT 2018 - 2023, BUMPER MOUNT CENTER

ETSSVBK05

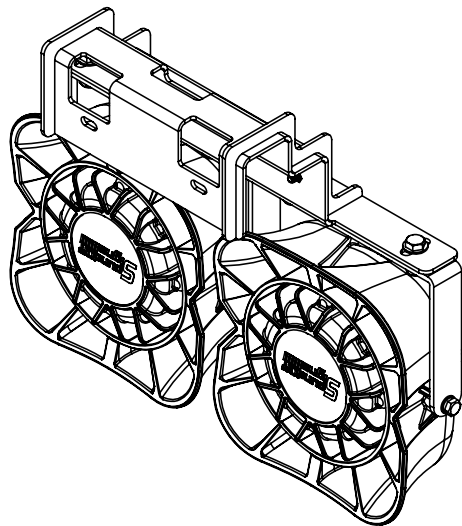

ETSSVBK05 PICTURED WITH ETSS100J SPEAKERS*

⚠ WARNING

- HIGH CURRENT interconnects must be properly terminated. Poor crimp quality can cause heat build-up and fire. Follow crimp connector manufacturer instructions.
- DO NOT install this product or route any wires in the Air Bag Deployment Zone. Refer to vehicle Owner's Manual for deployment zones.
- Do NOT use system to disconnect headlights, brake lights or other safety equipment.
- Unit may become hot to touch during normal operation.
- Failure to properly install connectors, fuses or wiring may cause vehicle failure or fire.
- Installation must only be performed by trained technician. Installer must determine vehicle wiring configuration and proper integration of system.
- Use proper wire gauge. All power wires connecting to positive (+) or negative (-) battery terminal or local chassis ground (-) must be sized to supply at least 125% of max. current and properly fused at power source.
- Install protective grommets when routing wire through firewall or metal.

NOTICE:

Installers and users must comply with all applicable federal, state and local laws regarding use and installation of warning devices.

Improper use or installation may void warranty coverage.

To review our Limited Warranty Statement & Return Policy for this or any SoundOff Signal product, visit our website at www.soundoffsignal.com/tech-services/returns/.

If you have questions regarding this product, contact **Technical Services**, Monday - Friday, 8 a.m. to 5 p.m. ET at 1.800.338.7337 (press #4).

Questions or comments that do not require immediate attention may be emailed to techservices@soundoffsignal.com.

INTRODUCTION:

CONTAINS	
QTY	COMPONENT
1	Speaker Bracket
4	1/4" - 20 x 3/4 Bolts
8	1/4" Washers
4	1/4" - 20 Nylon Nuts
2	10-32 x 3/4 Bolts
1	Installation Instruction Sheet
1	Product Warning Card

*Speaker and Bail Bracket Sold Separately

BRACKET COMPATIBLE WITH SPEAKERS:

- 100J
- 100N



1.800.338.7337 / www.soundoffsignal.com

100N/100J SERIES SPEAKER BRACKET (NO DRILL) CAPABLE OF HOLDING UP TO TWO SPEAKERS FOR THE DODGE DURANGO PURSUIT 2018 - 2023, BUMPER MOUNT CENTER

ETSSVBK05



- ### INSTALLATION:
1. Remove the front bumper cover assembly to access the bumper for speaker bracket installation. The assembly should be removed as one piece, not individually. Consult a local Dodge service center for best disassembly method. Keep all hardware.
 2. Remove the foam pad from the bumper by removing the two plastic push clips located on the bottom of the foam pad, as shown in Fig. 1. Keep all parts.
 3. Remove the plastic fascia support by removing the two bolts in the bumper, as shown in Fig. 2. Keep all hardware.
 4. Bumper should look like this with all foam and plastic removed, as seen in Fig 3.

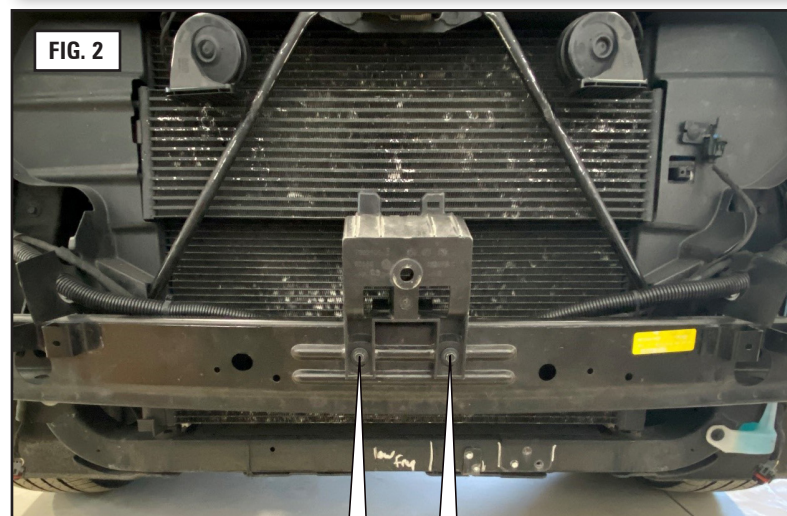

SoundOff
Signal 

1.800.338.7337 / www.soundoffsignal.com

100N/100J SERIES SPEAKER BRACKET (NO DRILL) CAPABLE OF HOLDING UP TO TWO SPEAKERS FOR THE DODGE DURANGO PURSUIT 2018 - 2023, BUMPER MOUNT CENTER

ETSSVBK05

FIG. 4

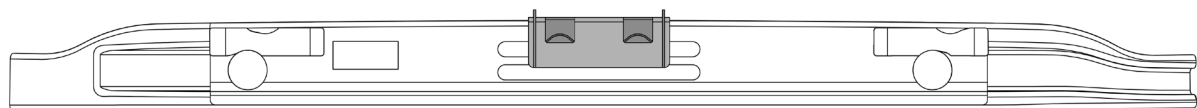
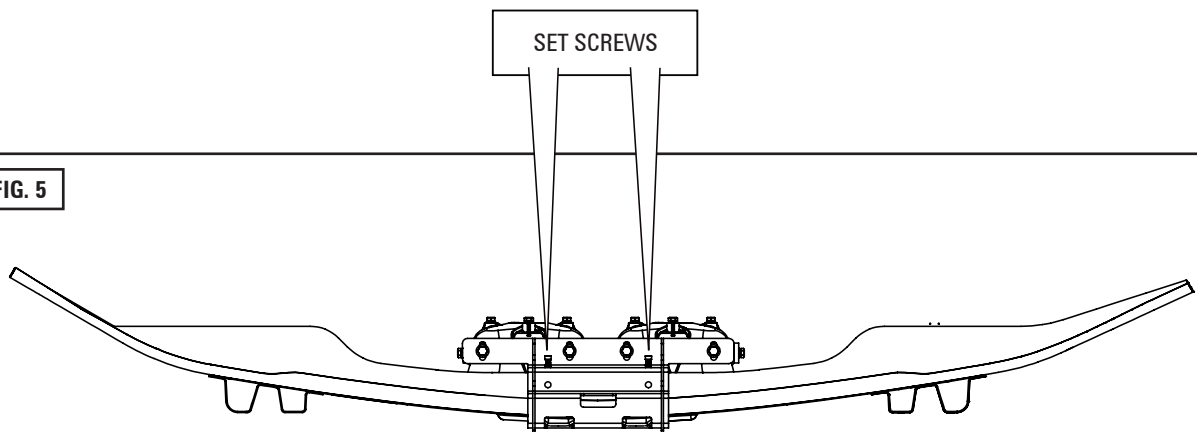

FIG. 5



INSTALLATION (CONT):

5. Place bumper speaker bracket over the bumper and align holes, as seen on Fig 4.
6. Place plastic fascia support in the holes on the bumper speaker bracket and attach the fasteners removed in Step 3.
7. Attach the speaker bail bracket to the bumper speaker bracket using the supplied speaker hardware, tighten to 10 ft-lb or fully secure.
8. Install the set screws into the bumper speaker bracket. The set screws provide pre load on bumper to help prevent vibration. These will not fully tighten.
9. The foam pad may need to be trimmed in order to properly fit around the bracket.
10. Install the foam pad.
11. Reinstall the front fascia using the factory hardware.

NOTICE:

Installers and users must comply with all applicable federal, state and local laws regarding use and installation of warning devices.

Improper use or installation may void warranty coverage.

To review our Limited Warranty Statement & Return Policy for this or any SoundOff Signal product, visit our website at www.soundoffsignal.com/tech-services/returns/.

If you have questions regarding this product, contact **Technical Services**, Monday - Friday, 8 a.m. to 5 p.m. ET at 1.800.338.7337 (press #4).

Questions or comments that do not require immediate attention may be emailed to techservices@soundoffsignal.com.

SoundOff Signal

1.800.338.7337 / www.soundoffsignal.com

ENHANCING SAFETY THROUGH INNOVATION