

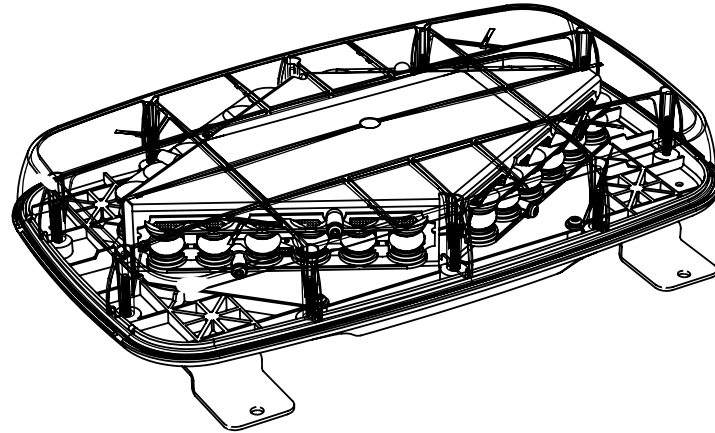

EPL7000 MINI LIGHTBAR PERMANENT MOUNT

- EPL7PF(x)C Low Bracket (shown)
- EPL7PF(x)A
- EPL7HF(x)C High Bracket
- EPL7HF(x)A



Please see reverse for Technical Specifications

⚠ WARNING

- HIGH CURRENT interconnects must be properly terminated. Poor crimp quality can cause heat build-up and fire. Follow crimp connector manufacturer instructions.
- DO NOT install this product or route any wires in the Air Bag Deployment Zone. Refer to vehicle Owner's Manual for deployment zones.
- Do NOT use system to disconnect headlights, brake lights or other safety equipment.
- Unit may become hot to touch during normal operation.
- Failure to properly install connectors, fuses or wiring may cause vehicle failure or fire.
- Installation must only be performed by trained technician. Installer must determine vehicle wiring configuration and proper integration of system.
- Use proper wire gauge. All power wires connecting to positive (+) or negative (-) battery terminal or local chassis ground (-) must be sized to supply at least 125% of max. current and properly fused at power source.
- Install protective grommets when routing wire through firewall or metal.



1.800.338.7337 / www.soundoffsignal.com

NOTICE:

Installers and users must comply with all applicable federal, state and local laws regarding use and installation of warning devices.

Improper use or installation may void warranty coverage.

To review our Limited Warranty Statement & Return Policy for this or any SoundOff Signal product, visit our website at www.soundoffsignal.com/tech-services/returns/.

If you have questions regarding this product, contact **Technical Services**, Monday - Friday, 8 a.m. to 5 p.m. ET at 1.800.338.7337 (press #4).

Questions or comments that do not require immediate attention may be emailed to techservices@soundoffsignal.com.

ENHANCING SAFETY THROUGH INNOVATION

INSTALLATION:

- 1) Determine a clean, flat location (typically roof) on the vehicle to mount the PINNACLE Mini Lightbar. The PINNACLE Mini Lightbar comes with two (2) steel brackets which should be used to permanently mount the light bar to a vehicle roof or similar horizontal surface.
- 2) Position the bar with brackets attached and mark hole centers. Center punch or drill pilot holes for a 1/4" sheet metal screw (customer supplied).
- 3) Place a locking washer over the screw and securely fasten the brackets to the mounting surface. The screws and holes should be caulked with a silicone based material to prevent leakage. **DO NOT OVERTIGHTEN!**
- 4) Make electrical connections.

Caution: Do not install this product or route any wires in the air bag deployment zone. Refer to your vehicle Owner's Manual for the location of any air bag deployment zones.



PINNACLE

Mini Lightbar

EPL7000 MINI LIGHTBAR PERMANENT MOUNT

TECHNICAL SPECIFICATIONS	
Overall Dimensions:	14.25"L x 8.27"W x 2.93"H
Flash Patterns:	29 flash patterns
Input Voltage Range:	10 - 16 Vdc
Current Consumption:	2 Amps (Avg) - 4 Amps (Max)
# of LEDs:	24 Generation 3 LEDs
Operating Temperature:	-40° to +65° C
Cord Length:	125.75"

FOLLOW DIAGRAM BELOW FOR ELECTRICAL CONNECTIONS

RED WIRE: Connect through a switch and fuse to 10-16Vdc
 BLACK WIRE: Connect to a good reliable ground (-)
 WHITE WIRE: Momentary, connect to 12V (+)

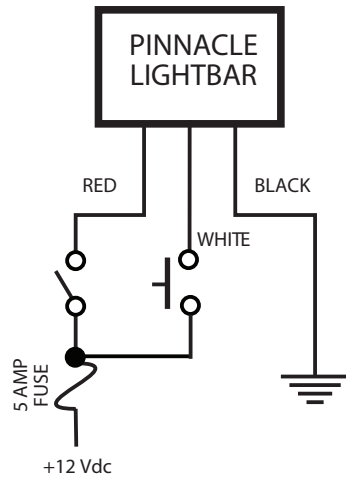

Flash Patterns	
Number/Name	Modules Affected
1. Warp	Alternating
2. Quad	"
3. Quad2	"
4. Quint	"
5. Double2	"
6. Warp 1, 2, 3	"
7. Progressive	"
8. Q-Switch™	"
9. Intercycle	"
10. Warp	Whole Bar
11. Quad	"
12. Quad2	"
13. Quint	"
14. Double2	"
15. Warp 1, 2, 3	"
16. Progressive	"
17. Warp	Diagonal
18. Quad	"
19. Quad2	"
20. Quint	"
21. Double2	"
22. Warp 1, 2, 3	"
23. Progressive	"
24. Q-Switch	"
25. Intercycle	"
26. Rotator	"
27. Cycle 1	Random
28. Cycle 2	"
29. Cruise	Whole Bar

ELECTRICAL:

PATTERN CHANGE

While the lightbar is operational, touch the WHITE WIRE to 10-16Vdc and hold for longer than 1.5 seconds. All light engines will steady burn, turn off, and then start flashing the next pattern on the list. Release the WHITE WIRE after the bar resumes flashing. If multiple pattern changes are required, the power must be cycled after every change.

The PINNACLE Mini Lightbar features non-volatile memory and will recall last pattern used. Selected pattern will remain the default once turned off and can be changed by changing the flash pattern before powering off.

ACTIVATE/DEACTIVATE CRUISE

While the lightbar is operational, touch the WHITE WIRE to 10-16Vdc for less than one second. The lightbar will enter cruise mode. The lightbar will remain in cruise mode unless power is cycled or the WHITE WIRE is touched to 10-16VDC for less than one second again.

REPLACEMENT PARTS & ACCESSORIES

- PMB3BKT- Replacement Permanent Mount Bracket (each)
- PMB3BRKT- Replacement Permanent Mount Bracket (kit)
- PMB3TDC- EPL7000 Replacement Clear Dome

NOTICE:

Installers and users must comply with all applicable federal, state and local laws regarding use and installation of warning devices.

Improper use or installation may void warranty coverage.

To review our Limited Warranty Statement & Return Policy for this or any SoundOff Signal product, visit our website at www.soundoffsignal.com/tech-services/returns/.

If you have questions regarding this product, contact **Technical Services**, Monday - Friday, 8 a.m. to 5 p.m. ET at **1.800.338.7337** (press #4).

Questions or comments that do not require immediate attention may be emailed to techservices@soundoffsignal.com.

SoundOff Signal

1.800.338.7337 / www.soundoffsignal.com

ENHANCING SAFETY THROUGH INNOVATION