

# GHOST®

## GHOST® SINGLE MULTI-MOUNT LIGHT, ECE CERTIFIED

### SINGLE LIGHT

EGHSTE1(x)B - Black  
EGHSTE1(x)W - White  
EGHSTE1(x)C - Chrome

## GHOST® SINGLE MULTI-MOUNT LIGHT, ECE65 CERTIFIED, XYLEX LENS

### SINGLE LIGHT

EGHSTE1(x)B-EU - Black  
EGHSTE1(x)W-EU - White  
EGHSTE1(x)C-EU - Chrome

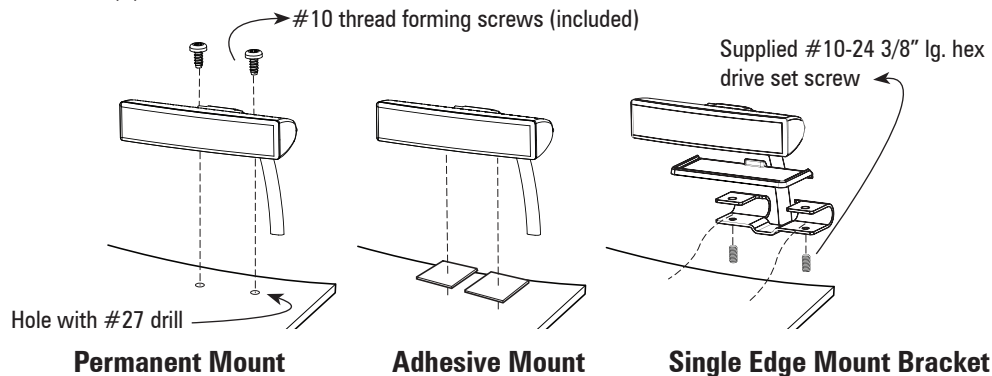

## ⚠ WARNING

- HIGH CURRENT interconnects must be properly terminated. Poor crimp quality can cause heat build-up and fire. Follow crimp connector manufacturer instructions.
- DO NOT install this product or route any wires in the Air Bag Deployment Zone. Refer to vehicle Owner's Manual for deployment zones.
- Do NOT use system to disconnect headlights, brake lights or other safety equipment.
- Unit may become hot to touch during normal operation.
- Failure to properly install connectors, fuses or wiring may cause vehicle failure or fire.
- Installation must only be performed by trained technician. Installer must determine vehicle wiring configuration and proper integration of system.
- Use proper wire gauge. All power wires connecting to positive (+) or negative (-) battery terminal or local chassis ground (-) must be sized to supply at least 125% of max. current and properly fused at power source.
- Install protective grommets when routing wire through firewall or metal.

**SoundOff**  
**Signal** 

1.800.338.7337 / www.soundoffsignal.com

## INSTALLATION:

### 1. Screw Mount

Establish a position on the vehicle. Use the mounting slots as a template to mark hole locations. Drill a hole using a #27 drill bit. The Torx screws provided are self-tapping.

Loosen the two #10 TORX screws on the back of each housing to adjust the angle of the GHOST. After adjustment, tighten the TORX screws.

### 2. Adhesive Mount

To obtain optimum adhesion, the bonding surfaces must be well unified, clean and dry. Peel one side of each adhesive mounting patch provided. Apply each rectangular patch to the bottom of the GHOST housing. Position the GHOST on the vehicle and mark 2 edges of the location using tape. Peel the remaining paper from the adhesive patch and carefully position the light using the tape template. Press down on housing firmly to insure good adhesive contact. Important: Apply carefully; adjustment is not possible after the adhesive bonds. Ultimate strength of adhesive is achieved after 24 hours.

Loosen the two #10 TORX screws on the back of each housing to adjust the angle of the GHOST. After adjustment, tighten the TORX screws.

### 3. New 'U' bracket for mounting on hood or trunk edge.

Open the hood or trunk that will be the attachment surface. Place the rubber pad provided on the surface, insuring that the lower lip is on the edge of the sheet metal. Fit the 'U' bracket to the back of the GHOST light base, nesting the bracket holes with the pins on the light base. Slide the assembly onto the rubber pad. Tighten the four set screws.

Loosen the two #10 TORX screws on the back of each housing to adjust the angle of the GHOST. After adjustment, tighten the TORX screws.

## NOTICE:

Installers and users must comply with all applicable federal, state and local laws regarding use and installation of warning devices.

*Improper use or installation may void warranty coverage. To review our Limited Warranty Statement & Return Policy for this or any SoundOff Signal product, visit our website at [www.soundoffsignal.com/support/](http://www.soundoffsignal.com/support/). If you have questions regarding this product, contact **Technical Services**, Monday - Friday, 8 a.m. to 5 p.m. or after hours 5 p.m. to 8 p.m. EST at 1.800.338.7337 (press #4 to skip the automated message). Questions or comments that do not require immediate attention may be emailed to [techservices@soundoffsignal.com](mailto:techservices@soundoffsignal.com).*

## OPERATION:

### WIRE CONNECTIONS

See setup procedure on second page.

The single GHOST comes equipped with an internal flasher with 3 user selectable patterns that can be synchronized either alternating or simultaneous with up to three other lights.

1. Connect the GHOST BLACK wire to a good, convenient ground.
2. Connect the GHOST RED wire to one side of a user supplied on/off switch. Connect the other side of the switch, through a 5Amp fuse, to a source of +10-30Vdc.
3. Cruise mode is activated by applying power to BROWN wire while RED wire is powered. NOTE: Cruise mode is STEADY-ON at 20% light output.
4. To sync lights and make pattern selections see reverse side.

## TECHNICAL SPECIFICATIONS

Overall Dimensions:	4" L x 0.88" H x 1.75" D
Input Voltage Range:	10-30 Vdc
Current Consumption:	0.75 Amps max/light (flash pattern dependent)
Light Sync Technology	Yes
Operating Temperature:	-20° to +65° C

## ⚠ WARNING

**This product contains high intensity LED devices. To prevent eye damage, DO NOT stare into light beam at close range.**

# GHOST

## SINGLE MULTI-MOUNT ECE65 CERTIFIED w/ STANDARD LENS

### SINGLE LIGHT

- EGHSTE1(x)B - Black
- EGHSTE1(x)W - White
- EGHSTE1(x)C - Chrome

## SINGLE MULTI-MOUNT ECE65 CERTIFIED w/ XYLEX LENS

### SINGLE LIGHT

- EGHSTE1(x)B-EU - Black
- EGHSTE1(x)W-EU - White
- EGHSTE1(x)C-EU - Chrome

#10 thread forming screws (included)

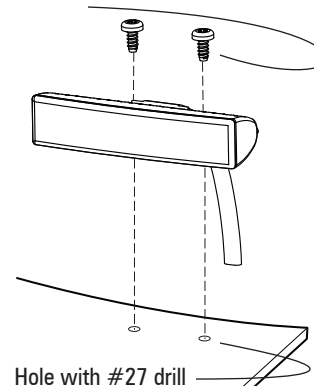

Permanent Mount

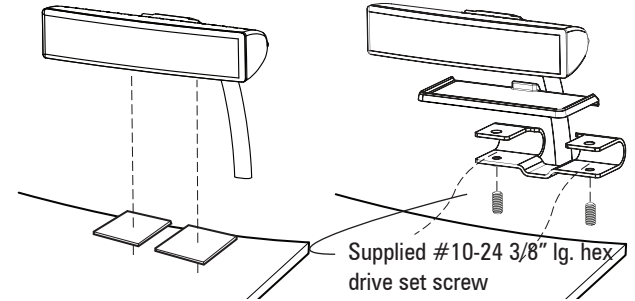

Adhesive Mount

Single Edge Mount Bracket

**NOTE:**  
The GHOST is a factory sealed unit that **CANNOT** be serviced in the field. Any attempt to gain access to the GHOST unit will most likely cause permanent damage and void its warranty.

### ECE GHOST Sync Configuration Instructions IMPORTANT! A MAXIMUM OF 4 SINGLE LIGHTS CAN BE SYNCED TOGETHER

1. Set ID#
  - a. Identify which pattern and sequence you want and look up ID# settings at right.
  - b. Connections
    - i. RED: +12Vdc
    - ii. WHT: +12Vdc (Note: you will need to disconnect after power is applied)
    - iii. BLK: Ground
  - c. Apply power to unit
  - d. Without disconnecting power from unit, disconnect WHT wire
  - e. Momentarily connect WHT to Ground to change ID #
    - i. Identify ID# by number of sequential flashes
    - ii. Possible ID#s: 1 – 4
  - f. Disconnect power from unit to get out of ID mode.
2. Set Pattern
  - a. Reapply power to units.
  - b. Once all Light Head ID#s are configured, make sure all lights are flashing the same pattern
  - c. Connect corresponding colored wires of all units together: RED to RED, etc.
  - d. Change Pattern
    - i. Momentarily touch WHT wires to Ground
    - ii. Observe pattern change on all lights connected
  - e. Insulate all wires by taping with electrical tape
3. Connect Master Switch for Application
  - a. **IMPORTANT!** Ensure WHT Pattern/Sync Wires are tied together

### ONE (1) LIGHT

Single Light Operation: Follow the ID Selection steps and set the ECE GHOST to ID#1 if it is not already.

### TWO (2) LIGHTS

**ALTERNATING:** To obtain Alternating patterns, follow the ID SELECTION steps and set one ECE GHOST to ID#1 and the other to ID#3. Then proceed to the PATTERN SELECTION steps.

**SIMULTANEOUS:** To obtain Simultaneous patterns, follow the ID SELECTION steps and set both ECE GHOST lights to ID#1. Then proceed to PATTERN SELECTION steps.

### SLAVE MODE

GHOST does not support Slave Mode.

### PATTERN RESET

1. Remove power
2. Place WHITE (sync) wire to ground
3. With sync wire grounded, re-power RED wire
4. Maintain for one second (light will dim)
5. Remove power and ground (pattern 1 set)

### Flash Patterns

Flash Patterns	FPM (Flashes per Minute)
1. Single	125
2. Double	125
3. Triple	123

### WIRE HOOK-UP TABLE

WIRE COLOR:	CONNECT TO:
RED	+10-30 Vdc
BLACK	Ground (-)
WHITE	ID/Pattern Select
BROWN WIRE	+10-30 Vdc

**SoundOff**  
**Signal** 

1.800.338.7337 / www.soundoffsignal.com