

GHOST®

GHOST® SINGLE SURFACE MOUNT LIGHT W/ PERMANENT MOUNT BRACKET

EGHST4(x)B-12 - Black
EGHST4(x)W-12 - White

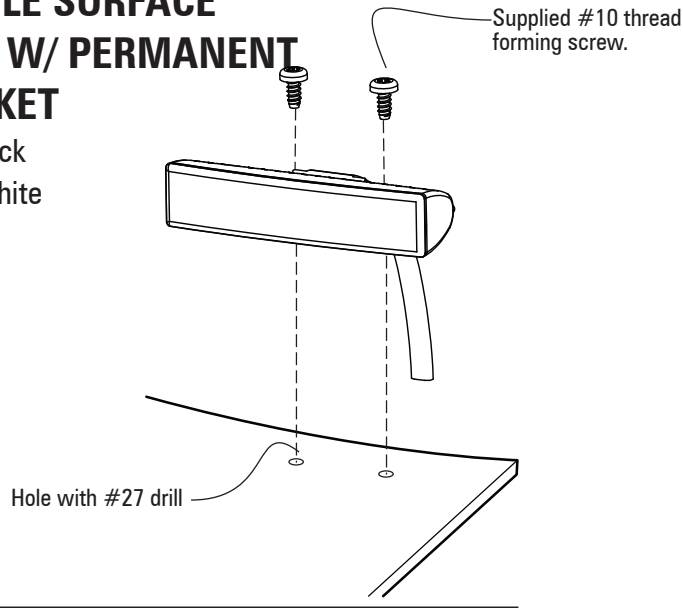

⚠ WARNING

- HIGH CURRENT interconnects must be properly terminated. Poor crimp quality can cause heat build-up and fire. Follow crimp connector manufacturer instructions.
- DO NOT install this product or route any wires in the Air Bag Deployment Zone. Refer to vehicle Owner's Manual for deployment zones.
- Do NOT use system to disconnect headlights, brake lights or other safety equipment.
- Unit may become hot to touch during normal operation.
- Failure to properly install connectors, fuses or wiring may cause vehicle failure or fire.
- Installation must only be performed by trained technician. Installer must determine vehicle wiring configuration and proper integration of system.
- Use proper wire gauge. All power wires connecting to positive (+) or negative (-) battery terminal or local chassis ground (-) must be sized to supply at least 125% of max. current and properly fused at power source.
- Install protective grommets when routing wire through firewall or metal.

Installers and users must comply with all applicable federal, state and local laws regarding use and installation of warning devices.

Improper use or installation may void warranty coverage. To review our Limited Warranty Statement & Return Policy for this or any SoundOff Signal product, visit our website at www.soundoffsignal.com/support/. If you have questions regarding this product, contact **Technical Services**, Monday - Friday, 8 a.m. to 5 p.m. or after hours 5 p.m. to 8 p.m. EST at 1.800.338.7337 (press #4 to skip the automated message). Questions or comments that do not require immediate attention may be emailed to techservices@soundoffsignal.com.

INSTALLATION:

WARNING! This product contains high intensity LED devices. To prevent eye damage, **DO NOT** stare into light beam at close range.

1. **Screw Mount** - Establish a position on the vehicle. Use the mounting slots as a template to mark hole locations. Drill a hole using a #27 drill bit. The Torx screws provided are self-tapping.
2. Loosen the two #10 TORX screws on the back of each housing to adjust the angle of the GHOST. After adjustment, tighten the TORX screws.

TECHNICAL SPECIFICATIONS

Overall Dimensions:	4.0"L x 0.88"H x 1.75"D
Input Voltage Range:	10-16Vdc
Current Consumption:	0.75A / Module*
# of LEDs:	6 Generation 3 LEDs
Operating Temperature:	-20° to +65° C
Light Sync Technology:	Yes

*Pattern Dependent

OPERATION:

WIRE CONNECTIONS

See setup procedure on second page. The single GHOST comes equipped with an internal flasher with 33 user selectable patterns that can be synchronized either alternating or simultaneous with up to three other lights.

1. Connect the GHOST BLACK wire to a good, convenient ground.
2. Connect the GHOST RED wire to one side of a user supplied on/off switch. Connect the other side of the switch, through a 5Amp fuse, to a source of +10-16Vdc.

NOTE: The GHOST is a factory sealed unit that CANNOT be serviced in the field. Any attempt to gain access to the GHOST™ unit will most likely cause permanent damage and void its warranty.

1 SINGLE LIGHT

Follow the ID selection steps and set the GHOST to the following ID:
 - Alternating (default): ID#1 or ID#3. (includes cycle patterns and steady burn patterns)
 - Simultaneous: ID#2 or ID#4. (both lights will flash together regardless of pattern)

(Continued on opposite side)

⚠ WARNING

This product contains high intensity LED devices. To prevent eye damage, **DO NOT** stare into light beam at close range.

NOTICE:

Installers and users must comply with all applicable federal, state and local laws regarding use and installation of warning devices.

Improper use or installation may void warranty coverage. To review our Limited Warranty Statement & Return Policy for this or any SoundOff Signal product, visit our website at www.soundoffsignal.com/support/. If you have questions regarding this product, contact **Technical Services**, Monday - Friday, 8 a.m. to 5 p.m. or after hours 5 p.m. to 8 p.m. EST at 1.800.338.7337 (press #4 to skip the automated message). Questions or comments that do not require immediate attention may be emailed to techservices@soundoffsignal.com.

**SoundOff
Signal**

1.800.338.7337 / www.soundoffsignal.com

SUPERIOR CUSTOMER RELATIONSHIPS. SMARTLY DESIGNED LIGHTING & ELECTRONIC SOLUTIONS.

EGHST4(xx)-12 7.17

GHOST®

GHOST® SINGLE SURFACE MOUNT LIGHT W/ PERMANENT MOUNT BRACKET

EGHST4(x)B-12 - Black

EGHST4(x)W-12 - White

2 SINGLE LIGHTS

Follow the ID selection steps and set the GHOST to the following ID:

IMPORTANT: Make sure both lights flash the same pattern!

- Both assemblies simultaneous with individual lights alternating.
 - Example: Driver/Passenger sim; Dr. (left alt right) Pass. (left alt right)
 - Set both GHOST Assemblies to ID#1
- Both assys. alternating with individual lights alternating.
 - EX: Dr./Pass. alt; Dr. (left. alt. right.) Pass. (right alt. left)
 - Set one GHOST to ID#1 and the other to ID#3
- Both assys. alternating with individual lights simultaneous
 - EX: Dr./Pass. alt; Dr. (left sim left) Pass. (right sim right)
 - Set one GHOST to ID#2 and the other to ID#4
- Both assys. simultaneous with individual lights simultaneous.
 - EX: Dr./Dr. sim; Dr. (left sim left) Pass. (right sim right)
 - Set both Ghost housings to ID#2

X-PATTERN - To obtain X-Patterns, follow the ID SELECTION steps and set one of the four GHOST lights to ID#1, one to ID#2, one to ID#3, and one to ID#4. Then proceed to the PATTERN SELECTION steps.

NOTE: Be sure to mount each GHOST in the correct placement based on ID#.

SLAVE MODE

GHOST does not support Slave Mode.

PATTERN SELECTION

1. Disconnect WHITE wire from any connections if applicable.
2. Turn GHOST ON.
3. Momentarily touching and removing the WHITE wire(s) to ground will advance the GHOST to the next flash pattern. Touching and removing the White wire for more than a few seconds will allow you to change the GHOST to the previous pattern. See flash pattern table. Continuing to touch and remove the WHITE wire(s) to ground will allow you to scroll through the pattern list. After pattern #33 is reached the list will start over again at pattern #1.

X-Pattern Sequence

ID#1 > ID#4 > ID#2 > ID#3

X-Pattern Light Head Placement

ID#4	ID#2
ID#3	ID#1

NOTE: The GHOST is equipped with flash pattern memory. Once you have selected a pattern the GHOST will always activate to that pattern every time the unit is turned on. Tape up and secure WHITE wire so that it will not accidentally change your selected pattern.

Ghost Sync Configuration Instructions

IMPORTANT! A MAXIMUM OF 4 SINGLE LIGHTS CAN BE SYNCED TOGETHER

1. Set ID#
 - a. Identify which pattern and sequence you want and look up ID# settings at left.
 - b. Connections
 - i. RED: +10-16Vdc
 - ii. WHT: +10-16Vdc (Note: you will need to disconnect after power is applied)
 - iii. BLK: Ground
 - c. Apply power to unit
 - d. Without disconnecting power from unit, disconnect WHT wire
 - e. Momentarily connect WHT to Ground to change ID #
 - i. Identify ID# by number of sequential flashes
 - ii. Possible ID#s: 1 – 4
 - f. Disconnect power from unit to get out of ID mode.
2. Set Pattern
 - a. Reapply power to units.
 - b. Once all Light Head ID#s are configured, make sure all lights are flashing the same pattern.
 - c. Connect corresponding colored wires of all units together: RED to RED, etc.
 - d. Change Pattern
 - i. Momentarily connect WHT wires to Ground
 - ii. Observe pattern change on all lights connected
 - e. Insulate all wires by taping with electrical tape
3. Connect Master Switch for Application
 - a. **IMPORTANT! Ensure WHT Pattern/Sync Wires are tied together**

PATTERN RESET

1. Remove power
2. Place WHITE (sync) wire to ground
3. With sync wire grounded, re-power RED wire
4. Maintain for one second (light will dim)
5. Remove power and ground (pattern 1 set)

Flash Patterns

Pattern Name	1 Light	Alternating 2 Lights	Simultaneous 2 Lights	X-Pattern 4 Lights	F.P.M. (Flashes / Minute)
1. Quint	x	x	x		70
2. Warp	x	x	x		350
3. Inter-Cycle Flash	x	x			
4. Double Flash	x	x	x		70
5. Quad Flash	x	x	x		80
6. PowerPulse	x	x	x		180
7. RoadRunner	x	x	x		113
8. Q-Switch	x	x			
9. RoadRunner Steady Burn	x	x			113
10. Quad Steady Burn	x	x			80
11. E-Ideal Single Flash	x	x	x		200
12. E-Ideal Double Flash	x	x	x		146
13. Quad2 Flash	x	x	x		67
14. Double2 Flash	x	x	x		95
15. X-Warp				x	
16. X-Double				x	
17. PowerRunner	x	x	x		
18. LCR Quint	x	x	x		
19. Warp?	x	x	x		
20. Ultra Warp	x	x	x		545
21. Thunder & Lightning	x	x			
22. Lite Speed	x	x	x		85
23. SuperSonic	x		x		170
24. LCR Lite Speed	x	x	x		
25. SuperSonic Ultra	x	x	x		
26. Tempo Shift	x	x	x		
27. Tempo Shift Warp	x	x	x		
28. SBE2	x	x	x		67
29. C²	x	x	x		200
30. U²	x	x	x		176
31. Ultra Glow	x	x	x		
32. Cyclone	x	x	x		
33. Chameleon	x	x	x		

