

DOMELIGHT, RECTANGULAR

ECVDMLTST2

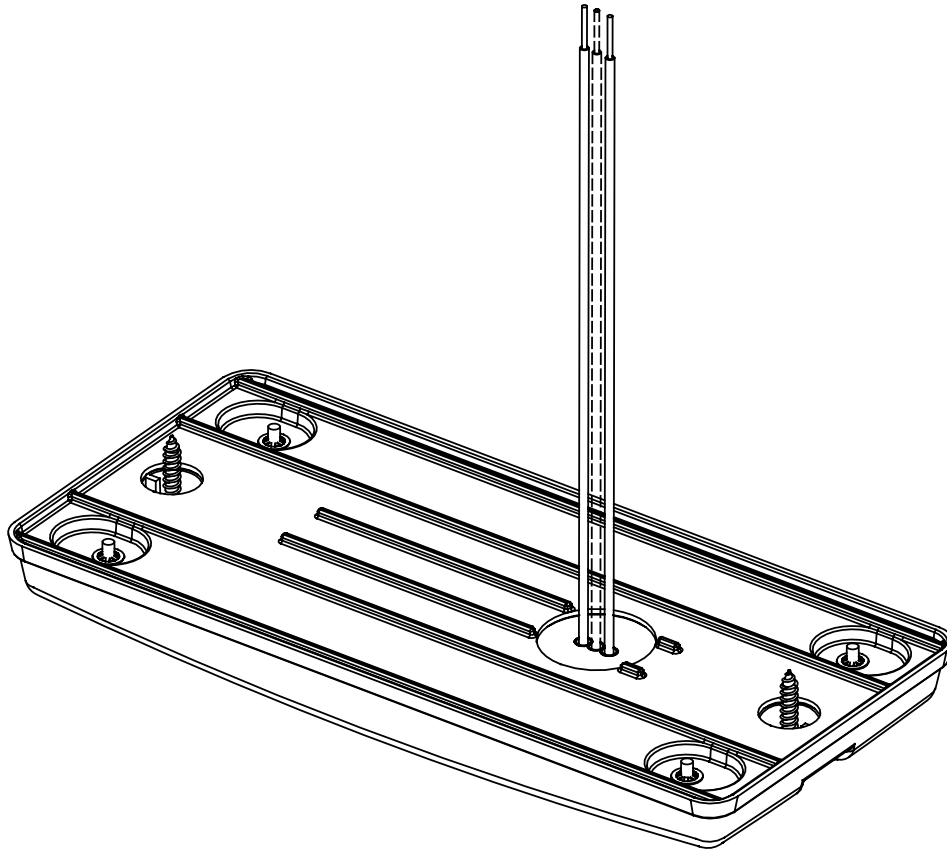

Important Information:

- DO NOT install this product or route any wires in the Air Bag Deployment Zone. Refer to your vehicle Owner's Manual for the location of any air bag deployment zones.



INSTALLATION:

1. Using the 2 holes in the Dome Light body as a template, mark and drill holes.
2. Mount the Dome Light using the (2) supplied mounting screws.

Technical Support: 1-800-338-7337

WIRING:

1. Connect the SoundOff Signal Dome Light's black wire to the vehicle's ground (-) wire.
2. Connect the SoundOff Signal Dome Light's red wire to the vehicle's positive (+) wire.
3. Connect the SoundOff Signal Dome Light's white wire (as applicable) to the vehicle's door switch wire.

TECHNICAL SPECIFICATIONS

Overall Dimensions:	7.03"L x 3.28"W x 0.74"H
Input Voltage Range:	10 - 30 Vdc
Current Consumption:	<0.65 amps
Operating Temperature:	-40° to +65° C
# of LEDs:	15 LEDs



To review our Limited Warranty Statement & Return Policy for this or any SoundOff Signal product please visit our website at www.soundoffsignal.com and select the "Warranty & Returns" link along the left column of our home page. If you have questions regarding this product please contact Technical Services, Monday - Friday, 8 am to 5 pm at 1.800.338.7337, press #4 to skip the automated message. Questions or comments that do not require immediate attention may be emailed to techsupport@soundoffsignal.com.

1.800.338.7337. / www.soundoffsignal.com / Thank you for trusting us with your safety!